



# **Boiler Product Line Brochure**





Lochinvar, LLC  
300 Maddox Simpson Pkwy  
Lebanon, TN 37090  
615-889-8900 / Fax: 615-547-1000  
[www.Lochinvar.com](http://www.Lochinvar.com)



# Contents

From the Solution™ to the CREST®, Lochinvar Boilers are noted for their range of benefits and application flexibility. Collectively, they represent the most complete product line in the industry. From a company with a long history of innovation and a reputation for excellence.

You'll find there's a Lochinvar product for any application imaginable – from standard residential units to state-of-the-art commercial products. And with selection, comes opportunity.

In fact, the diversity and performance of our product line is surpassed only by it's quality—in design, construction, and training. A commitment that is reinforced by the Lochinvar Tech Center, a state-of-the-art testing and training facility equipped with the very latest in CAD/CAM technology and a comprehensive R&D lab.

Quality, efficiency, features, service, and selection. For more than 90 years, these have been the hallmarks of Lochinvar products.

Lochinvar...the innovator in boiler technology.



This emblem means a product has a NO<sub>x</sub> rating which exceeds the requirements of the South Coast Air Quality Management District and Texas Commission of Environmental Quality.



This emblem means the Stack Frame is available for use with that product. See page 27 for details.

This catalog is designed to provide a convenient, condensed overview of the entire Lochinvar boiler product line. For a complete list of features, specifications and technical data on a particular product, see the full line catalog, your local distributor or contact Lochinvar. Every Lochinvar product is designed and built to meet or exceed the fuel efficiency and safety standards of one or more of these agencies, wherever applicable.

CREST®	1
SYNC®	3
Power-Fin®	5
KNIGHT® XL	7
Copper-Fin II®	9
Copper-Fin®	11
Copper-Fin® Atmospheric	13
KNIGHT®	15
Solution™	21
Buffer Tanks/ Hydraulic Separators	23
Squire® Buffer Tank	24
Squire® Stainless Steel	25
Stack Frame	27
Low Temperature Valve	29
Electric Boilers	30



# CREST<sup>®</sup> CONDENSING BOILER

## Fire Tube Innovation up to 5 Million Btu/Hr

Lochinvar<sup>®</sup> has taken the fire-tube concept in an innovative new direction with the CREST<sup>®</sup> modulating-condensing boiler. With sizes that range from 1.5 to 5 million Btu/hr, you finally have the opportunity to utilize Lochinvar leading-edge technology in your largest applications. With thermal efficiencies up to 99% in low water temperature applications, CREST is positioned to provide exceptional energy-saving performance.

The advanced CREST introduces a combustion system with a unique burner design with up to 25:1 turndown. The burner fires into an array of 316L stainless steel fire-tubes that transfer the heat to the surrounding water with exceptionally high efficiency.

CREST communicates seamlessly and in real time with building management systems by utilizing an on-board Modbus protocol. The SMART TOUCH<sup>™</sup> control has a built-in cascading feature that communicates with up to eight units, providing total command without an external control or complex and expensive control logic programming by the BMS integrator.

Yes, innovative fire-tube boiler technology integrated with our SMART TOUCH<sup>™</sup> operating control makes the CREST a genuine game-changer among commercial boilers.



UP TO 99% THERMAL EFFICIENCY



## Advanced Negative Regulation Technology

CREST safely and reliably operates with supply gas pressure as low as 4 inches water column. Because Negative Regulation (Neg/Reg) technology draws fuel gas into a pre-mix combustion system instead of relying on utility pressure through the gas valve, operation is steady in low gas pressure systems or when peak demands occur on supply lines. Plus, Neg/Reg automatic fan speed control fine-tunes the correct fuel/air ratio entering the burner, providing even, consistent combustion for a cleaner burning flame achieving high combustion efficiency.



## Fully Modulating up to 25:1 Turndown

25:1 turndown means the burner can fire at a rate as low as 4% of its maximum input. For example, a 2 million Btu/hr CREST unit can modulate from 80,000 up to 2,000,000 Btu/hr depending on demand. High turndown greatly reduces “short cycling” when demand is low. All boiler systems are designed to provide enough heat to maintain a facility’s heat loss on the coldest days. When the system is zoned, the CREST’s high turndown works to match the actual system demand and, in return, reduces the customer’s fuel bill and provides better comfort by load matching the heat loss of the system. Greater seasonal efficiencies will be realized due to the extremely large turndown offered by CREST.

## As Low As 35 GPM\* to Full 350 GPM Flow Rates

CREST allows system designers tremendous flexibility to vary the flow rate through the boiler. It can service systems that operate with widely fluctuating flow rates depending on demand. CREST can be installed with primary/secondary piping or in a full-flow arrangement. Typical design techniques include full-flow systems or variable flow systems using variable frequency drives on the heating water pumps. In either case, CREST excels in these applications and allows the flow through the boiler to vary based on system demand. \* 25 GPM min. flow on FB1500 model, 50 GPM on FB5000 model.

## Built-in Cascading Sequencer

Sequences up to an 8-boiler system using simple 2-wire daisy-chain connection, eliminating cost and uncertainty of separate “third party” sequencer. On demand, one boiler functions as the leader and modulates to capacity. Increasing load then “cascades” to additional “lag” boilers in sequence as needed. Lead-lag rotation shifts “first on” boiler role every 24 hours, distributing equal lead-lag runtimes to each unit.

CREST’s ability to sequence up to eight units that each have as much as 25:1 turndown means that the combined system has the potential of operating with modulation of up to 200:1 turndown. A bank of eight 2.0M Btu CRESTs would be able to provide as little as 80,000 Btu/hr and as much as 16,000,000 Btu/hr of heating output. In addition, the CREST Cascade can be set for “Efficiency Optimization” with each boiler firing at the same low BTU/hr input rates to receive the benefits of the highest thermal efficiency.

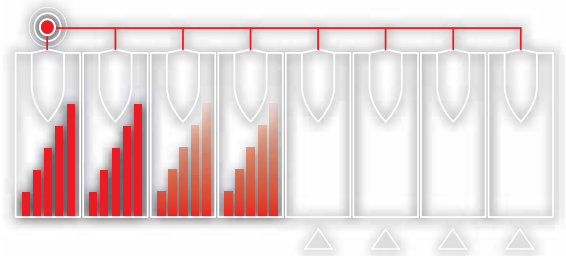



# CREST® Boiler Dimensions & Specifications

CONDENSING BOILER  
**CREST**®

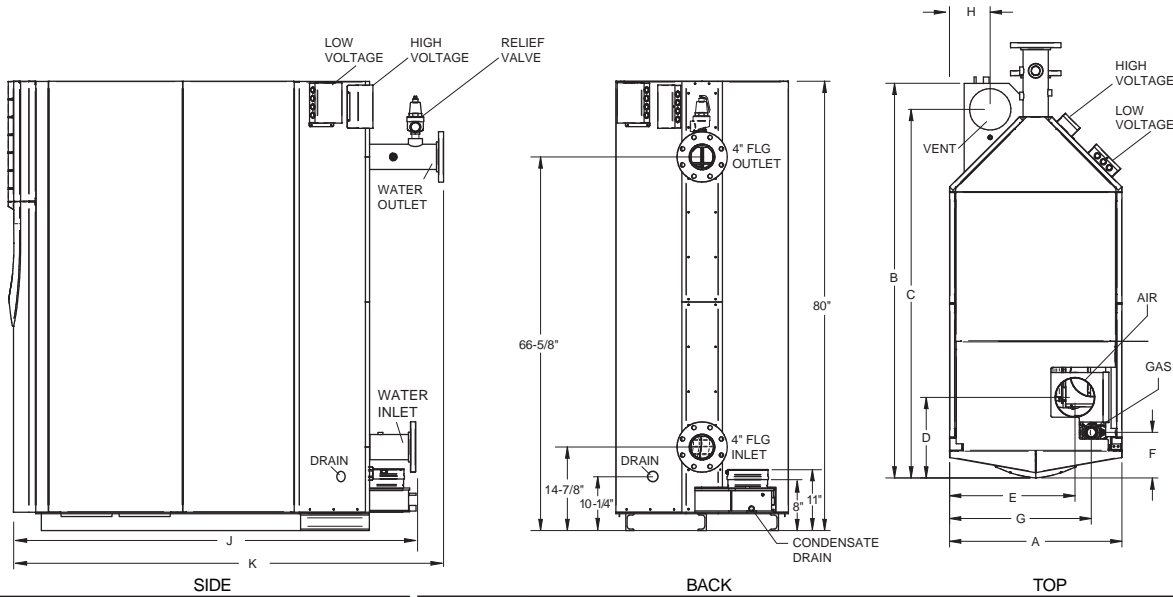

CREST HEATING BOILER								DIMENSIONS AND SPECIFICATIONS														
Model Number	Input MBH Min.	Input MBH Max.	AHRI Thermal %	Output MBH	NET I=B=R MBH	Turndown*		A	B	C	D	E	F	G	H	J	K	Gas Conn.	Air Inlet	Vent Size	Operating Wt. (lbs.)	Shipping Wt. (lbs.)
FBN1500	60	1,500	92.0%	1,380	1,200	25:1		30-3/4"	71-1/2"	65-3/4"	14-3/8"	22-3/8"	8-1/2"	25-1/4"	8-1/8"	72-5/8"	77-5/8"	1-1/2"	7	7	2,496	1,900
FBN2000	80	2,000	92.0%	1,840	1,600	25:1		30-3/4"	71-1/8"	65-1/8"	14-7/8"	22-3/8"	8-1/4"	25-3/8"	9-5/8"	71-7/8"	76-7/8"	1-1/2"	8	8	3,054	2,150
FBN2500	125	2,500	92.0%	2,300	2,000	20:1		34-1/4"	76-3/8"	70-1/4"	17-3/4"	26-1/8"	9-3/4"	27-3/8"	11-3/8"	78"	83"	2"	8	9	3,652	2,560
FBN3000	150	3,000	92.0%	2,760	2,400	20:1		40-1/2"	83-5/8"	76-3/8"	17-3/8"	31-3/8"	9-7/8"	34-3/4"	11-1/2"	82-1/8"	87-1/8"	2"	10	10	4,126	2,920
FBN3500	200	3,500	92.0%	3,220	2,800	18:1		40-1/2"	83-1/4"	75-5/8"	17-1/4"	31-3/8"	9-7/8"	34-3/4"	12-7/8"	81-1/8"	86-1/8"	2"	10	10	4,744	3,225
FBN4000	335	4,000	93.0%	3,720	3,235	12:1		53-1/2"	109"	100-3/4"	31-1/4"	40-3/4"	14-1/2"	45-3/4"	12-3/4"	109-1/4"	108-1/4"	2-1/2"	12	12	6,900	4,750
FBN5000	500	5,000	93.0%	4,650	4,043	10:1		53-1/2"	109"	100-3/4"	28"	40-3/4"	11"	45-1/2"	12-3/4"	109-1/4"	108-1/4"	2-1/2"	14	14	8,000	5,550

Notes: Indoor installation only. All information subject to change. Change "N" to "L" for LP gas models. For Low NOx on FB2500 - FB5000 models, consult factory.  
\*Turndown rate reduced on LP gas models.

## SMART TOUCH™ FEATURES

- **SMART TOUCH™ Touchscreen Operating Control**
- **Full-Color 8" Touchscreen LCD Display**
- **Built-in Cascading Sequencer for up to 8 Boilers**
- Cascade Multiple Sized Boilers
- Lead/Lag Cascade
- Efficiency Optimized Cascade
- **Front-End Loading Capability with CopperFin II and Powerfin Boilers**
- **Building Management System Integration with 0-10 VDC Input**
- **Modbus Communications**
- **Outdoor Reset Control with Outdoor Air Sensor**
- **Password Security**
- **Domestic Hot Water Prioritization**  
DHW tank piped with priority in the boiler loop  
DHW tank piped as a zone in the system with the pumps controlled by the Smart System  
DHW Modulation Limiting  
Separately Adjustable SH/DHW Switching Times  
Low Water Flow Safety Control & Indication  
Inlet & Outlet Temperature Readout  
Freeze Protection  
Service Reminder  
Time Clock
- **Data Logging**  
Hours Running, Space Heating  
Hours Running, Domestic Hot Water  
Hours Running, Modulation Rate  
Ignition Attempts  
Last 10 Lockouts
- **Programmable System Efficiency Optimizers**  
Night Setback  
Anti-Cycling  
Outdoor Air Reset Curve  
Ramp Delay  
Boost Temperature & Time
- **Three Pump Control**  
System Pump  
Boiler Pump  
Domestic Hot Water Pump

- **High-Voltage Terminal Strip**  
120 VAC / 60 Hertz / 1 Phase Power Supply (FB1500-3500)  
208 VAC / 60 Hertz / 3 Phase Power Supply (FB4000-5000)  
System Pump, Boiler Pump and DHW Pump Power
- **Low-Voltage Terminal Strip**  
24 VAC Auxiliary Device Relay  
Auxiliary Proving Switch Contacts  
Alarm on Any Failure Contacts  
Runtime Contacts  
DHW Thermostat Contacts  
Unit Enable/Disable Contacts  
System Sensor Contacts  
DHW Tank Sensor Contacts  
Outdoor Air Sensor Contacts  
Cascade Contacts  
0-10 VDC BMS External Control Contact

## STANDARD FEATURES

- Up to 93% Thermal Efficiency (AHRI)
- Up to 99% Thermal Efficiency in Low Temperature Applications
- Modulating Burner with up to 25:1 Turndown
- Direct-Spark Ignition
- Low-NOx Operation
- Sealed Combustion
- Low Gas Pressure Operation
- Vertical or Horizontal Venting
- Category IV Venting up to 100 Feet
- ASME "H" Stamped Heat Exchanger
- 316L Stainless Steel Fire Tubes
- 160 psi Working Pressure
- On/Off Switch
- Adjustable High Limit with Manual Reset
- Low Water Cutoff with Manual Reset & Test
- High & Low Gas Pressure Switches w/Manual Reset
- Low Air Pressure Switches
- Condensate Trap w/ Blocked Drain Switch

- Drain Valve
- System Sensor
- Outdoor Air Sensor
- Inlet & Outlet Temperature Sensors
- High Voltage Terminal Strip
- Low Voltage Terminal Strip
- Downstream Gas Test Cocks
- 50 psi ASME Relief Valve
- Temperature & Pressure Gauge
- Zero Clearances to Combustible Materials
- 10-Year Limited Warranty (See Warranty for Details)
- 1-Year Warranty on Parts (See Warranty for Details)

## OPTIONAL EQUIPMENT

- Alarm Bell
- BMS Gateway - BACnet or LonWorks
- Condensate Neutralization Kit
- SMART TOUCH PC Software
- Common Vent Kits
- Dual Fuel Gas Train
- Electrical Options (Shipped Loose):  
208V/3Ø/60Hz (Models FB1500-3500 only)  
480V/3Ø/60Hz  
600V/3Ø/60Hz

## CODES & REGISTRATIONS

- ANSI Z21.13/CSA Certified
- ASME certified, "H" Stamp / National Board
- California Code Compliant
- CSD1 / Factory Mutual / GE Gap Compliant
- South Coast Air Quality Management District Qualified
- Canadian Registration Number (CRN)
- AHRI Certified

U.S. Patent # 8,286,594



CONDENSING BOILER

## Building on a Tradition of Innovation

Lochinvar's commitment to research and development once again brings innovation to the industry! The SYNC™ Commercial Boiler combines stainless steel heat exchanger technology with Modulating Condensing combustion to deliver thermal efficiencies as high as 98% in low-temperature applications.

With models at 1.0, 1.3 and 1.5 million BTU/hr inputs, SYNC will serve a large range of commercial applications and add the “green” touch that building owners and facility managers desire.

SYNC also reaches new levels of innovation with SMART TOUCH™... touchscreen technology that puts total operational control at your fingertips! With SMART TOUCH, it's easier than ever to set up a perfectly synchronized “green” system, and access a complete onboard database of real-time operational data and performance history.

Other features in SYNC include space-saving footprints, direct-vent design with intake and exhaust runs up to 100 feet, and a built-in cascading sequencer for up to 8 boilers, delivering up to 12 million BTU/hr heating capacity.



UP TO 98% THERMAL EFFICIENCY



### Total Control, at Your Fingertips

The full-color SMART TOUCH Main Menu screen is your gateway to complete control of all SYNC functions, and total access to system performance data and history. Do it all and see it all right here, using our SMART TOUCH software.

### Direct-Venting up to 100 Feet

SYNC offers tremendous flexibility for building plan placement because it permits direct-vent air intake and exhaust runs up to 100 equivalent feet using PVC, CPVC, Polypropylene or AL29-4C stainless steel vent pipe. Intake and exhaust runs can terminate horizontally through a sidewall or vertically through

### Advanced Negative Regulation Technology

SYNC safely and reliably operates with supply gas pressure as low as 4 inches water column, because Negative Regulation (Neg/Reg) technology automatically adjusts fan speed to ensure the correct volume of fuel and air entering the burner.

### “Fail-Safe” Direct-Spark Ignition

With each call for heat, two electrodes ignite the fuel/gas mixture. A third electrode then senses for flame. SMART TOUCH will lock out and display the fault if ignition does not occur.

### Two-in-One Stainless Steel Heat Exchanger

A primary heat exchanger combined with a secondary exchanger captures flue gas heat and allows very low return water temperatures and does not require a low-temperature bypass. The stainless steel, pH-tolerant design features a weld-sealed assembly with no O-rings or gaskets, and does not require special glycol. ASME Section IV approved and stamped.

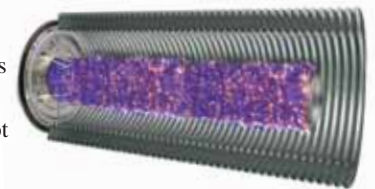

### Fully Modulating Burner

SMART TOUCH allows fully modulating combustion with 10:1 turndown. The combustion system can operate as low as 10% of maximum input, and modulates the firing rate up to 100% as demand increases. The burner design incorporates a woven steel mesh sleeve over a stainless steel burner tube and fires in a 360° pattern along the entire length of the primary heat exchanger. These together allow SYNC's compact size to excel compared to units with larger multiple burners.



### Built-in Cascading Sequencer

Sequences up to an 8-boiler system using simple 2-wire daisy-chain connection, eliminating cost and uncertainty of separate “third party” sequencer. On demand, one boiler functions as the “leader”, and modulates to capacity. Increasing load then “cascades” to additional “lag” boilers in sequence as needed. Lead-lag rotation shifts “first on” boiler role every 24 hours, distributing equal lead-lag runtimes to each unit.

# SYNC™ Boiler Dimensions & Specifications

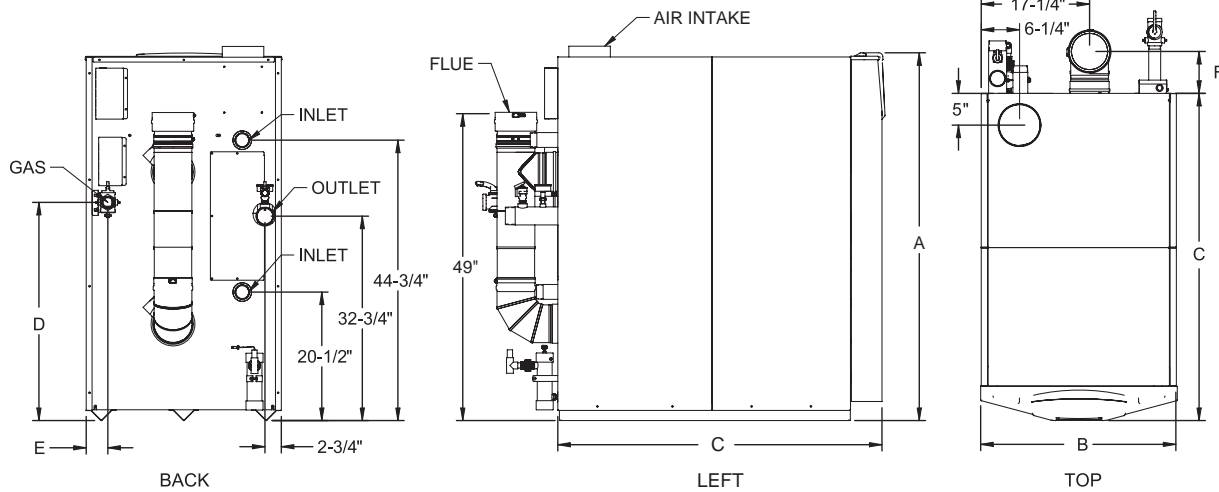

SYNC HEATING BOILER						DIMENSIONS AND SPECIFICATIONS											
Model Number	Input		Thermal Efficiency	Output MBH	Net I=B=R MBH	A	B	C	D	E	F	Gas Conn.	Inlet Water Conn.	Outlet Water Conn.	Air Inlet	Vent Size	Shipping Wt. (lbs.)
	Min. MBH	Max. MBH															
SBN1000	100	1,000	94.1%	941	818	58-3/4"	31"	48"	35"	4-1/2"	15"	1-1/2"	2" x 2"	3"	6"	6"	786
SBN1300	130	1,300	95.4%	1,240	1,078	58-3/4"	31"	52-1/4"	34-3/4"	3-1/2"	6-3/4"	1-1/2"	2" x 2"	3"	6"	6"	856
SBN1500	150	1,500	96.2%	1,443	1,255	58-3/4"	31"	56-1/2"	34-3/4"	3-1/2"	6-3/4"	1-1/2"	2" x 2"	3"	6"	6"	926

Notes: Change 'N' to 'L' for L.P. Gas Model. No deration on L.P. models. Performance data based on manufacturer test results. 120 VAC / 15 AMP circuit required. All dimensions shown in inches.

## STANDARD FEATURES

- Up to 96.2% Thermal Efficiency
- Modulating Burner with 10:1 Turndown
  - Direct-Spark Ignition
  - Low NOx Operation
  - Sealed Combustion
  - Low Gas Pressure Operation
- Vertical & Horizontal Venting
  - Category IV Venting up to 100 Feet
  - PVC, CPVC, Polypropylene or AL29-4C Vent Material
  - Sidewall Vent Terminations Provided
- ASME Stainless Steel Heat Exchanger
  - ASME Certified, "H" Stamped
  - Gasketless Design
  - 160 psi Working Pressure
- On/Off Switch
- Adjustable High Limit with Manual Reset
- Low Water Cutoff with Manual Reset & Test
- Low Air Pressure Switch
- High & Low Gas Pressure Switches with Manual Reset
- Inlet & Outlet Temperature Sensors
- Two Easy Access Terminal Strips
- Downstream Test Cocks
- 50 psi ASME Relief Valve
- Temperature & Pressure Gauge
- Zero Clearance to Combustible Material
- Approved for Combustible Floor Installation
- 1 Year Warranty on Parts
- 10 Year Limited Warranty (see warranties for details)

## SMART TOUCH™ FEATURES

- SMART TOUCH™ Touchscreen Operating Control
  - Full-Color Touchscreen LCD Display
  - Built-in Cascading Sequencer for up to 8 Boilers
  - Building Management System Integration with 0-10 VDC Input
  - Outdoor Reset Control with Outdoor Air Sensor
  - Dual Level Password Security
  - Domestic Hot Water Prioritization
  - Low Water Flow Safety Control & Indication
  - Inlet & Outlet Temperature Readout
  - Freeze Protection
  - Service Reminder
  - Time Clock
- Data Logging
  - Hours Running, Space Heating
  - Hours Running, Domestic Hot Water
  - Ignition Attempts
  - Last 10 Lockouts
- Programmable System Efficiency Optimizers
  - Night Setback
  - Anti-Cycling
  - Outdoor Air Reset Curve
  - Boost Temperature & Time
- Three Pump Control
  - System Pump
  - Boiler Pump
  - Domestic Hot Water Pump

- High Voltage Terminal Strip
  - 120 VAC / 60 Hertz / 1-Phase Power Supply
- Three Sets of Pump Contacts
- Low Voltage Terminal Strip
  - 24 VAC Auxiliary Device Relay
  - Auxiliary Proving Switch Contacts
  - Flow Switch Contacts
  - Alarm on Any Failure Contacts
  - Runtime Contacts
  - DHW Thermostat Contacts
  - Unit Enable/Disable Contacts
  - System Sensor Contacts
  - DHW Tank Sensor Contacts
  - Outdoor Air Sensor Contacts
  - Cascade Contacts

## OPTIONAL EQUIPMENT

- Alarm Bell
- Condensate Neutralization Kit
- SMART SYSTEM PC Software
- Modbus Communications
- BMS Gateway to BacNet of LON
- Stainless Steel Vent Kits

## CODES & REGISTRATIONS

- ANSI Z21.13a / CSA Certified
- ASME certified, "H" stamp
- California Code compliant
- CSD1 / FM / GE Gap
- Massachusetts Code compliant
- South Coast Air Quality Management District registered

Registered under U.S. Patent # 7,506,617

### The Next Generation

The latest generation of Power-Fin continues to evolve, with new “Built-in Advantages” from Lochinvar Corporation®. These include expanded burner modulation and the advanced SMART SYSTEM™ operating control, including a built-in cascading sequencer for up to eight boilers. It has been designed to operate more efficiently at lower inputs, which can add up to big savings. Plus, with numerous venting capabilities, the Power-Fin is even more flexible to install. And it’s easy to see how the Power-Fin is performing thanks to a digital control panel. Take a look at what the next generation of Power-Fin has to offer.

### SMART SYSTEM™ Control

- Built-in cascading sequencer controls up to 8 units
- 2-line 16-character LCD readout of setup, system status and diagnostic data in words, not codes.
- Password security
- Pump control for operation of water heater pump
- Pump delay w/freeze protection
- Low NOx operation
- 0-10 Vdc BMS input for easy integration into Building Management Systems
- Optional SMART SYSTEM PC software for advanced setup and diagnostics



87% THERMAL EFFICIENCY



### Infinite Modulation

With thermal efficiencies up to 87%, Power-Fin boilers feature infinitely modulating burner firing rates (turndown), precisely matching the firing rate to domestic water load requirements. The result is better overall efficiency and less cycling. Power-Fin boilers may be specified as either 5:1 turndown (502 - 2001), 2:1 turndown (1501 - 2001), or 100% ON/OFF (502 - 1302). With 5:1 turndown the burner fires as low as 20% of maximum input when demand is lowest and increases the firing rate up to 100% as demand increases. Models with 2:1 turndown modulate from 50% to 100% of maximum input.

### Gasketless Heat Exchanger

The Power-Fin heat exchanger features an array of 20 or 24 copper-finned tubes surrounding the burner for maximum heat transfer. Lochinvar also pioneered the “gasketless” heat exchanger, which eliminates the use of O-rings and gaskets. Because of the time-proven reliability of this design, the Power-Fin heat exchanger is backed by a 5 year limited warranty.

### Venting Options

#### DirectAire Horizontal

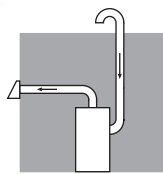

Vents horizontally up to 50 equivalent feet using Category IV vent materials. Draws combustion air up to 50 ft. from a different pressure zone.

#### Direct Vent

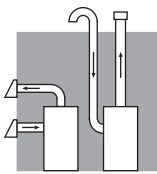

Horizontal or vertical venting up to 50 equivalent feet using Category IV vent materials. Draws combustion air from the same pressure zone. This option only available with 5:1 (M) firing code models.

#### Sidewall

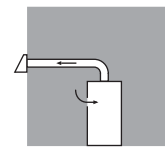

Horizontal venting up to 50 equivalent feet using Category IV vent materials. Draws combustion air from the room.

#### DirectAire Vertical

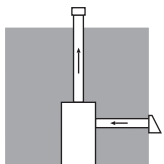

Vertical venting up to 50 equivalent feet using Category I or IV vent materials. Draws combustion air up to 50 ft. from a different pressure zone.

#### Common Venting

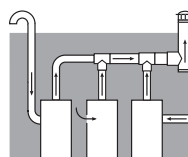

Vents multiple units vertically through one vent termination with Category II vent materials and draws combustion air from the room, roof or sidewall. Vent kit and Category IV to II conversion kit required.

#### Vertical

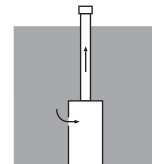

Vertical venting using Category I or Category IV vent materials. Draws combustion air from the room.



# Power-Fin® Boiler Dimensions & Specifications

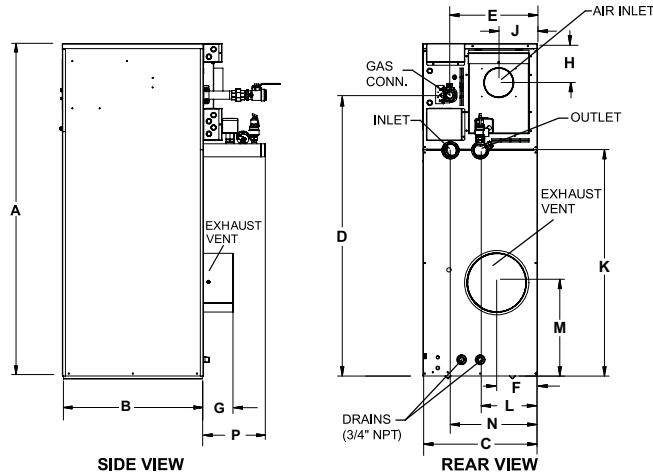

POWER-FIN BOILER							DIMENSIONS AND SPECIFICATIONS								
Model Number	Input MBH	B9/F9 Thermal Efficiency	Output MBH	Net I=B=R MBH	M9 Thermal Efficiency	Output MBH	Net I=B=R MBH	A	B	C	D	B9/F9 E	M9 E	F	G
PBN0502	500	85.0%	425	370	85.0%	425	370	44-1/2"	28-1/2"	23-1/4"	34"	17-3/4"	19-1/2"	6-1/2"	6"
PBN0752	750	85.0%	638	554	85.0%	638	554	52"	28-1/2"	23-1/4"	41-1/2"	17-3/4"	19-1/2"	6-3/4"	6"
PBN1002	999	85.0%	850	739	85.0%	850	739	59-1/4"	28-1/2"	23-1/4"	48-3/4"	17-3/4"	19-1/2"	7-1/4"	6"
PBN1302	1,300	85.0%	1,105	961	85.0%	1,105	961	67-3/4"	28-1/2"	23-1/4"	57-1/4"	17-3/4"	19-1/2"	8-1/4"	6"
PBN1501	1,500	84.0%	1,260	1,096	85.0%	1,275	1,109	65-1/2"	29-3/4"	27-1/4"	58-3/4"	21"	21"	13-1/2"	8"
PBN1701	1,700	84.0%	1,428	1,242	85.0%	1,445	1,257	70"	29-3/4"	27-1/4"	63-1/4"	21"	21"	13-1/2"	8"
PBN2001	2,000	84.0%	1,680	1,461	85.0%	1,700	1,478	76-3/4"	29-3/4"	27-1/4"	70"	21"	21"	13-1/2"	8"

Model Number	H	J	K	L	M	N	B9/F9 P	M9 P	Gas Conn.	Air Inlet	B9/F9 Cat I	M9* Cat II	M9 Cat IV	Shipping Wt. (lbs)
PBN0502	8"	7-3/4"	23"	11-1/2"	11-1/4"	17-1/2"	15-1/4"	15-1/4"	1"	5"	7"	7"	4"	505
PBN0752	8"	7-3/4"	30-1/2"	11-1/2"	11-1/4"	17-1/2"	15-1/4"	15-1/4"	1-1/4"	5"	9"	9"	5"	554
PBN1002	8"	7-3/4"	37-3/4"	11-1/2"	11-1/4"	17-1/2"	15-1/4"	15-1/4"	1-1/4"	6"	10"	10"	6"	603
PBN1302	8"	7-3/4"	46-1/4"	11-1/2"	19-1/2"	17-1/2"	15-1/4"	15-1/4"	1-1/4"	6"	12"	12"	8"	652
PBN1501	10"	9-1/2"	43-1/2"	5-3/4"	22-1/4"	21-1/2"	24-1/2"	19-1/2"	1-1/2"	6"	12"	8"	6"	1,065
PBN1701	10"	9-1/2"	48"	5-3/4"	25"	21-1/2"	24-1/2"	19-1/2"	1-1/2"	7"	14"	9"	7"	1,100
PBN2001	10"	9-1/2"	54-3/4"	5-3/4"	27-1/2"	21-1/2"	24-1/2"	19-1/2"	1-1/2"	8"	14"	10"	8"	1,127

Notes: Change 'N' to 'L' for LP Gas Model. No deration on LP models. All water connections are 2-1/2" \*w/CAT II conversion kit

## STANDARD FEATURES

- Up to 87% Thermal Efficiency (M)
- Up to 85% Thermal Efficiency (B/F)
- Modulating Burner with 5:1 Turndown
  - Hot Surface Ignition
  - Low NOx Operation
  - Sealed Combustion
  - Low Gas Pressure Operation
- Vertical & Horizontal Venting
  - Venting up to 50 Feet
  - Category I or Category IV Venting
  - Cat IV converts to Cat II w/ optional vent kit
- ASME Copper-Finned Tube Heat Exchanger
  - ASME Certified, "H" Stamped
  - Gasketless design
  - 160 psi working pressure
- On/Off Switch
- Adjustable High Limit w/ Manual Reset
- Flow Switch
- Low Air Pressure Switch
- Downstream Test Cocks
- 50 psi ASME Relief Valve
- Combustion Air Filtration
- Temperature & Pressure Gauge
- Zero Clearances to Combustible Material
- 1 Year Warranty on Parts
- 10 Year Limited Warranty (See Warranties for Details)

## SMART SYSTEM FEATURES

- SMART SYSTEM Operating Control
  - 2 line, 16 Character Display
  - Dual Level Password Security
  - Domestic Hot Water Prioritization
  - Built in Cascading Sequencer for up to 8 Boilers
  - Building Management System Integration with 0-10 VDC Input
  - Outdoor Reset Control with Outdoor Air Sensor
  - Low Water Flow Safety Control & Indication
  - Inlet & Outlet Temperature Readout
  - Freeze Protection
  - Service Reminder
  - Time Clock
- Data Logging
  - Hours Running, Space Heating
  - Hours Running, Domestic Hot Water
  - Ignition Attempts
  - Last 10 Lockouts
- Programmable System Efficiency Optimizers
  - Night Setback
  - Anti-Cycling
  - Outdoor Air Reset Curve
  - Ramp Delay
  - Boost Temperature & Time

## Three Pump Control

- System Pump
- Boiler Pump
- Domestic Hot Water Pump
- High Voltage Terminal Strip
  - 120 VAC / 60 Hertz / 1 Phase Power Supply
  - Three sets of Pump Contacts with Pump Relays
- Low Voltage Terminal Strip
  - 24 VAC Auxiliary Device Relay
  - Auxiliary Proving Switch Contacts
  - Flow Switch Contacts
  - Alarm on Any Failure Contacts
  - Runtime Contacts
  - DHW Thermostat Contacts
  - Room Thermostat Contacts
  - System Sensor Contacts
  - DHW Tank Sensor Contacts
  - Outdoor Air Sensor Contacts
  - Cascade Contacts
  - 0-10 VDC BMS External Control Contact

## FIRING CONTROL SYSTEMS

- M Indicates 5:1 Turndown, Category IV
- B Indicates 2:1 Turndown, Category I
- F Indicates 100% On/Off Fire, Category I
- M9 Standard
- B9 or F9 Special Order, Factory Trimmed
- M7, B7 or F7 California Code
- M13, B13 or F13 CSD1/FM/GE Gap

## OPTIONAL EQUIPMENT

- Alarm Bell
- Cupro-Nickel Heat Exchanger
- High & Low Gas Pressure Switches w/ Manual Reset
- Low Water Cutoff w/ Manual Reset & Test
- SMART SYSTEM PC Software
- Vent Kits:
  - Horizontal Exhaust Cap
  - Horizontal Air Intake Cap
  - Horizontal Direct Vent Kit
  - Category IV to Category II Conversion Kit

Registered under U.S. Patent # 7,506,617

POWER-FIN® 500,000 - 2,000,000 Btu/hr models



## The Smartest Choice for Condensing Boiler Performance

The KNIGHT® XL, engineered with Lochinvar's exclusive SMART SYSTEM™ control and an array of other innovative features, places it far ahead of any commercial heating boiler in its class. It promises and delivers ultimate ease of installation and maintenance. With up to 94.6% thermal efficiency, low-NOx emissions and a fully modulating burner, it is the best "green choice" for today's environmentally focused market.

Five modulating/condensing stainless steel KNIGHT XL boilers are available with 399,999–800,000 Btu/hr inputs and remarkably small space-saving footprints. All are equipped for direct-vent installation with air intake and exhaust runs up to 100 feet using PVC, CPVC, Polypropylene or AL29-4C vent materials. This range of choices is ideal for light-duty applications such as small hotels, schools and office buildings. For higher-demand applications, up to eight KNIGHT XL units can be installed utilizing the built-in cascading sequencer to deliver up to 6.4 million Btu/hr heating capacity.



UP TO 94.6% THERMAL EFFICIENCY



### SMART SYSTEM™ Control

SMART SYSTEM provides unequalled control and monitoring functions that are easy to understand and use.



- Multi-Color Graphic LCD Display
- Navigation Dial
- USB Port
- Modbus Capability (Optional)
- DHW Modulation Limiting
- DHW Night Setback\*
- Controls up to three different setpoint temperatures
- 0-10 V Boiler Rate Output
- 0-10V Signal to control variable speed boiler pump\*
- 0-10V System Pump Signal Input\*
- Heat Demand from 0-10V Input
- Installer to Program Name and Number into the Boiler
- Freeze Protection Parameters Installer Adjustable
- Separately adjustable SH/DHW Switching times\*
- Installer access to BMS and ramp delay settings

*\*Exclusive to Lochinvar Smart System*

### Advanced Negative Regulation Technology

KNIGHT XL safely and reliably operates with supply gas pressure as low as 4 inches water column. Negative Regulation (Neg/Reg) technology automatically adjusts fan speed that ensures the correct volume and mix of fuel and air throughout the firing range.

### Two-in-One Stainless Steel Heat Exchanger

A primary heat exchanger combined with a secondary heat exchanger captures flue gas heat and condenses to utilize available latent energy. The stainless steel, pH-tolerant design features a weld-sealed assembly with no O-rings or gaskets and does not require special glycol. ASME Section IV approved and stamped.



### Fully Modulating Burner

The SMART SYSTEM allows fully modulating combustion with 5:1 turndown. The burner can fire as low as 20% of maximum input and modulates the firing rate up to 100% as demand increases. The burner is a single stainless steel assembly covered with woven steel mesh and fires in a 360° pattern along the entire length of the primary heat exchanger. This allows the compact KNIGHT XL to exceed the capacity of units with larger multiple burners.



### Direct Venting up to 100 Feet

KNIGHT XL offers 7 venting options and tremendous flexibility for placement of units within the building, because it permits direct-vent air intake and exhaust runs up to 100 equivalent feet using either PVC, CPVC, Polypropylene or AL29-4C stainless steel vent pipe. A sidewall vent termination kit is shipped standard with every KNIGHT boiler.

# KNIGHT XL® Boiler Dimensions & Specifications

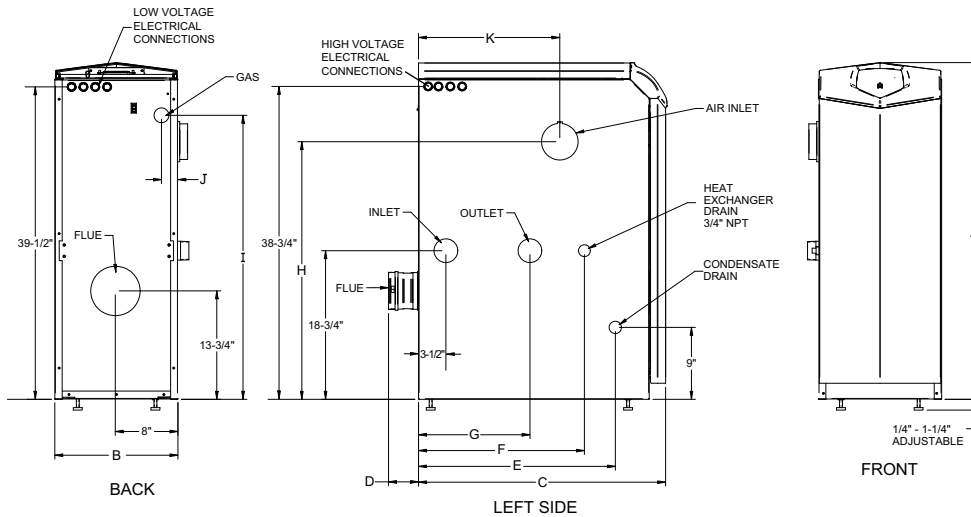

## KNIGHT® XL HEATING BOILER

Model Number	Input Min MBH	Input Max MBH	Thermal Efficiency	Output MBH	Net I=B=R MBH
KBN400	80	399	93.3%	373	324
KBN501	100	500	93.3%	467	406
KBN601	120	600	94.6%	567	493
KBN701	140	700	94.3%	660	574
KBN801	160	800	94.0%	752	654

## DIMENSIONS AND SPECIFICATIONS

A	B	C	D	E	F	G	H	I	J	K	Gas Conn.	Water Conn.	Air Inlet	Vent Size	Shipping Wt. (lbs.)
42-1/2"	15-1/2"	27-3/4"	3-3/4"	20-3/4"	21"	14"	34"	34"	2"	18-3/4"	1"	1-1/2"	4"	4"	280
42-1/2"	15-1/2"	31-1/2"	3-3/4"	25-1/2"	21"	14"	32-1/2"	36"	2"	18"	1"	1-1/2"	4"	4"	310
42-1/2"	15-1/2"	36-1/4"	3-3/4"	25"	21"	14"	36"	32-3/4"	5-1/2"	19-1/2"	1"	2"	4"	4"	340
42-1/2"	15-1/2"	40-1/4"	3-3/4"	29"	23"	17"	36"	32-3/4"	3-1/4"	23-1/2"	1"	2"	4"	6"	370
42-1/2"	15-1/2"	45-1/4"	3-3/4"	33-1/4"	23"	17"	36"	32-3/4"	3-1/4"	27-3/4"	1"	2"	4"	6"	405

Notes: Indoor installation only. All information subject to change. Change "N" to "L" for LP gas models.

### STANDARD FEATURES

- Up to 94.6% Thermal Efficiency
- Modulating Burner with 5:1 Turndown
  - Direct-Spark Ignition
  - Low NOx Operation
  - Sealed Combustion
  - Low Gas Pressure Operation
- ASME Stainless Steel Heat Exchanger
  - ASME Certified, "H" Stamped Gasketless Heat Exchanger
  - 160 psi Working Pressure
  - 50 psi ASME Relief Valve
  - Highly efficient, condensing design
- Vertical & Horizontal Direct-Vent
  - Category IV venting up to 100 feet
  - PVC, CPVC, Polypropylene or AL29-4C Venting up to 100 Feet
  - Factory Supplied Sidewall Vent Termination
- Smart System™ Control
- Other Features
  - On/Off Switch
  - Adjustable High Limit w/ Manual Reset
  - Automatic Reset High Limit
  - Flow Switch
  - Flue Temperature Sensor
  - Low Air Pressure Switch
  - Temperature & Pressure Gauge
  - Adjustable Leveling Legs
  - Condensate Trap
  - Zero Clearances to Combustible Material
  - 10 Year Limited Warranty (See Warranty)

### SMART SYSTEM FEATURES

- SMART SYSTEM Digital Operating Control
  - Multi-Colored Graphic LCD Display w/ Navigation Dial
- Three Reset Temperature Inputs with curves for three set point temperature inputs
- Built in Cascading Sequencer for up to 8 Boilers
  - Multiple Size Boiler Cascade
  - Lead Lag
  - Efficiency Optimization
  - Front End Loading with Copper-Fin II®
- Outdoor Reset Control with Outdoor Air Sensor
- Programmable System Efficiency Optimizers
  - Night Setback
  - DHW Night Setback
  - Anti-Cycling
  - Outdoor Air Reset Curve
  - Ramp Delay
  - Boost Temperature & Time
- Three Pump Control
  - System Pump With Parameter for Continuous Operation
  - Boiler Pump With Variable Speed Pump Control\*
  - Domestic Hot Water Pump
- Domestic Hot Water Prioritization
  - DHW tank piped with priority in the boiler loop
  - DHW tank piped as a zone in the system with the pumps controlled by the Smart System
  - DHW Modulation Limiting
  - Separately Adjustable SH/DHW Switching Times\*
- Building Management System Integration
  - 0-10VDC Input to Control Modulation or Set Point
  - 0-10VDC Input Signal from Variable Speed System Pump\*
  - 0-10VDC Modulation Rate Output
  - 0-10VDC Input to Enable/Disable call for heat
  - Access to BMS Settings through Display

### High Voltage Terminal Strip

- 120 VAC / 60 Hertz / 1 Phase Power Supply
- Three sets of Pump Contacts with Pump Relays

### Low Voltage Terminal Strip

- 24 VAC Device Relay
- Proving Switch Contacts
- Flow Switch Contacts
- Alarm on Any Failure Contacts
- Runtime Contacts
- DHW Thermostat Contacts
- 3 Space Heat Thermostat Contacts
- System Sensor Contacts
- DHW Tank Sensor Contacts
- Outdoor Air Sensor Contacts
- Cascade Contacts
- 0-10 VDC BMS External Control Contact
- 0-10 VDC Boiler Rate Output Contacts
- 0-10 VDC Variable Speed System Pump Signal Input
- 0-10 VDC Signal to Control Variable Speed Boiler Pump
- Modbus Contacts

### Time Clock

### Data Logging

- Hours Running, Space Heating
- Hours Running, Domestic Hot Water
- Ignition Attempts
- Last 10 Lockouts

### Other Features

- Low Water Flow Safety Control & Indication
- Password Security
- Inlet & Outlet Temperature Readout
- Customizable Freeze Protection Parameters
- Custom Maintenance Reminder with Contractor Info

\*Exclusive feature, available only from Lochinvar

### FIRING CONTROL SYSTEMS

- M9 Standard Construction
- M7 California Code
- M13 CSD1 / FM / GE Gap (KB501-KB801)

### OPTIONAL EQUIPMENT

- Alarm Bell
- Condensate Neutralization Kit
- Concentric Vent Kit (KB400-KB601)
- BMS Gateway to LON or BacNet
- High & Low Gas Pressure Switches w/ Manual Reset (KB501-KB801)
- MODBUS Communication
- Multi Temperature Loop Control
- Low Water Cutoff w/Manual Reset & Test
- Boiler Circulation Pump
- SMART SYSTEM PC Software
- Stainless Steel Vent Kits (KB701-KB801)
- Stack Frame



# COPPER-FIN II<sup>®</sup>

## The Foundation of Lochinvar Becomes Stronger

Copper-finned tube, non-condensing appliances are the foundation of Lochinvar's success. In 1993, Lochinvar introduced the Copper-Fin II, the first horizontal chassis copper-finned tube boiler to operate with fan-assisted combustion. Now, the Copper-fin II is even better. Along with high thermal efficiency, gasketless heat exchangers and multiple venting options we have added Lochinvar's exclusive SMART SYSTEM™ control.



Nine models from 399,999 to 2,070,000 Btu/hr input provide you with exceptional products with a long list of new features in addition to the established features which redefined the industry. The Copper-fin II was the first proportional fired, fan-assisted boiler on the market. Every model features a small footprint for easy passage through a 36" door, low NOx – third party tested to less than 20 PPM, Stack Frames that can put twice the Btu/hr input in the same space and vent diameters up to 8" smaller than conventional atmospheric boilers.

### SMART SYSTEM Puts More Control and Information at your Fingertips

The most exciting addition to the Copper-Fin II is the SMART SYSTEM™ control. The SMART SYSTEM is an advanced, state of the art integrated operating control. We introduced the SMART SYSTEM control in 2005 and it has delivered proven operation in thousands of demanding commercial applications. The control provides the installer, owners and operators with precise temperature control and diagnostic information.



#### Advanced features include:

- 2-Line, 16 Character LCD display of Setup, System Status and Diagnostic Data in Words, not codes
- Built-in Cascade sequencer controlling up to 8 Boilers
- Outdoor Reset adjusts setpoint based on reset curve
- Domestic hot water prioritization allows the boiler to provide space heating and produce domestic hot water all in one system
- 0-10 VDC BMS Input to control boiler operation
- Modbus protocol - optional

UP TO 85% THERMAL EFFICIENCY



### Proportional Firing

Proportional firing divides a single manifold of multiple burners into smaller, independent stages.

With up to four stages of individual operation, the Smart System control can reduce the firing rate down to approximately 25% Btu/hr input. This simple but effective design matches the boiler's firing capacity to the constantly changing system demand. Full Fire or On/Off combustion systems often fire the entire gas train in short, inefficient bursts. Stage firing delivers the Btu's required in smoother and longer burn cycles which will improve operation and reduce component fatigue.

STACK FRAME

### Gasketless Heat Exchanger

In 1989, Lochinvar was the first water heater manufacturer to offer gasketless cast iron & copper-finned tube heat exchangers. Our unique gasketless design enhances reliability by eliminating o-rings and gaskets found on other brands. The heat exchanger features glass lined headers and copper-finned tubes with extruded integral fins spaced 7-fins per inch for exceptional heat transfer. The heat exchanger is built to ASME construction standards for 160 psi working pressure and is backed by a ten year limited warranty.

### Venting Options

#### Conventional

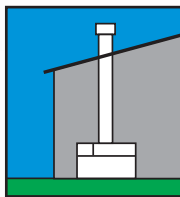

Vents into conventional flue or vent breaching using Type B double wall vent.

#### Sidewall

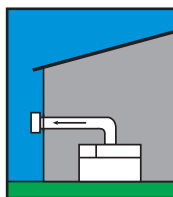

Draws fresh air from inside the room. Vents up to 50 equivalent feet directly through the outside wall without the need for a powered sidewall cap.

#### DirectAire Vertical w/ Sidewall

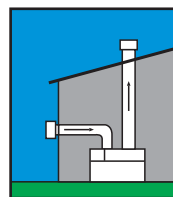

Draws fresh air from outside and vents through conventional vertical flue.

#### Outdoor

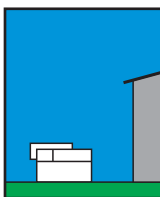

Requires optional outdoor vent cap. Use when indoor space is a problem or if outdoor location gives better access.

#### Powered Sidewall

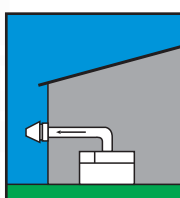

Vents directly through the outside wall using an optional powered sidewall cap. Ideal when a vent stack is not practical.

#### DirectAire Vertical

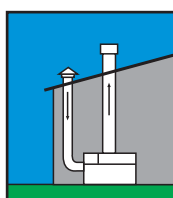

Draws fresh air from outside and vents through conventional vertical flue.

#### Power DirectAire Horizontal

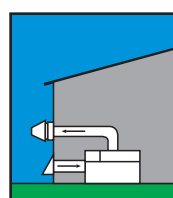

Draws fresh air from outside and vents through sidewall using optional powered vent cap.

#### Aire-Lock Direct Vent

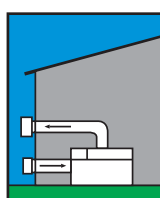

Draws fresh air 50 equivalent feet from a sidewall. Vents horizontally up to 50 equivalent feet through the sidewall.



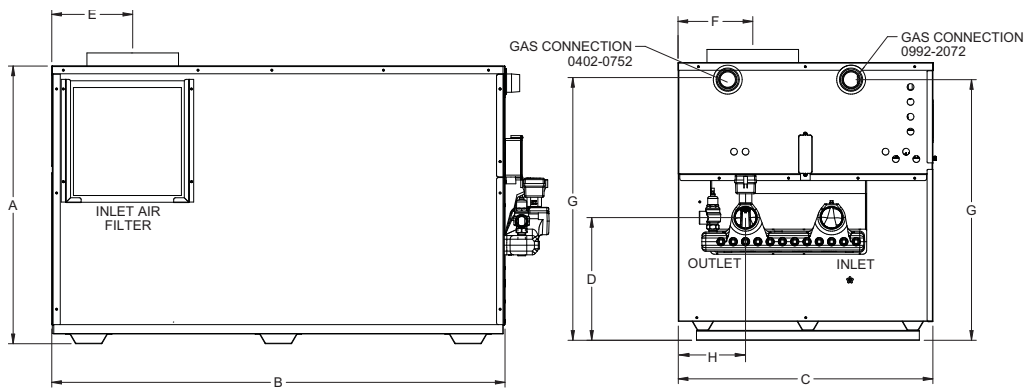

Copper-Fin II Heating Boiler					Dimensions & Specifications											
Model Number	Input MBH	Thermal Efficiency	Output MBH	Net I=B=R MBH	A	B	C	D	E	F	G	H	Vent	Air	Gas	Shipping
													Size	Inlet	Conn	Weight
CHN0402	399	85%	339	295	31-1/2"	37-3/4"	22-1/4"	12-1/2"	7"	7"	29"	6-1/2"	6"	6"	1-1/4"	378
CHN0502	500	85%	425	370	31-1/2"	45-1/2"	22-1/4"	12-1/2"	7"	7"	29"	6-1/2"	6"	6"	1-1/4"	414
CHN0652	650	85%	553	481	31-1/2"	56-3/4"	22-1/4"	12-1/2"	8-1/2"	8-1/4"	29"	6-1/2"	8"	8"	1-1/4"	500
CHN0752	750	85%	638	555	31-1/2"	64"	22-1/4"	12-1/2"	8-1/2"	8-1/4"	29"	6-1/2"	8"	8"	1-1/4"	543
CHN0992	990	85%	842	732	36"	48-1/4"	33-1/2"	15-3/4"	8-1/2"	8-1/2"	33-3/4"	8-3/4"	10"	10"	2"	773
CHN1262	1,260	85%	1,071	931	36"	58-1/2"	33-1/2"	15-3/4"	10-1/2"	9-1/2"	33-3/4"	8-3/4"	12"	12"	2"	863
CHN1442	1,440	85%	1,224	1,064	36"	68-3/4"	33-1/2"	15-3/4"	10-1/2"	10-1/2"	33-3/4"	8-3/4"	12"	12"	2"	965
CHN1802	1,800	85%	1,530	1,330	36"	82-1/4"	33-1/2"	15-3/4"	11"	11"	33-3/4"	8-3/4"	14"	12"	2"	1,100
CHN2072	2,070	85%	1,760	1,530	36"	92-1/2"	33-1/2"	15-3/4"	11"	11"	33-3/4"	8-3/4"	14"	12"	2"	1,219

Notes: Change 'N' to 'L' for LP gas models. No deration on LP models. Water connections for models CH 0402-0752 are 2" NPT on 6-1/2" centers. Header increases "B" dimension 3-1/2" for models CH 0402-0752 and 6-1/4" for models CH 0992-2072. Water connections for models CH 0992-2072 are 2-1/2" NPT on 11-1/4" centers. Performance data is based on manufacturer test results.

## STANDARD FEATURES

- 85% Thermal Efficiency (AHRI Certified)
- Proportional Firing up to 4:1 Turndown
  - Hot Surface Ignition
  - Low NOx Operation
  - Sealed Combustion
  - Low Gas Pressure Operation
- Vertical & Horizontal Venting
  - Category I Venting
    - Double Wall "B" Vent Material
  - Category IV Venting
    - AL29-4C Stainless Steel Vent Material
- ASME Copper Finned Tube Heat Exchanger
  - ASME Certified, "H" Stamped
  - Gasketless design
  - 160 psi working pressure
- On/Off Switch
- Combustible Floor Rated (0992 - 2072)
- Adjustable High Limit w/ Manual Reset
- Flow Switch
- Low Air Pressure Switch
- Inlet & Outlet Temperature Sensors
- Easy Access Terminal Strips
- Downstream Test Cocks
- 50 psi ASME Pressure Relief Valve
- Temperature & Pressure Gauge
- 1 Year Warranty on Parts (See Warranty for Details)
- 10 Year Limited Warranty (See Warranty for Details)

## OPTIONAL EQUIPMENT

- Alarm Bell
- High & Low Gas Pressure Switches w/ Manual Reset
- Cupro-Nickel Heat Exchanger
- Low Water Cut Off, Probe Type w/ Manual Reset & Test
- Modbus Communications
- BMS Gateway to Lon or Bac Net
- Combustible Floor Kit (0402-0752)
- Stack Frame

## SMART SYSTEM™ FEATURES

- SMART SYSTEM™ Operating Control
  - 2 Line/16 Character LCD Display
  - Built in Cascading Sequencer for up to 8 boilers
  - Front End Loading with Crest or KNIGHT boilers
  - Building Management System Integration with 0-10 VDC Input
  - Outdoor Reset Control with Outdoor Air Sensor
  - Password Security
  - Domestic Hot Water Prioritization
  - Low Water Flow Control & Indication
  - Inlet & Outlet Temperature Readout
  - Freeze Protection
  - Service Reminder
  - Time Clock
  - 0-10 VDC Rate Output
  - Condensing Protection
  - 0-10 VDC System Pump Speed Input
- Data Logging
  - Hours Running, Space Heating
  - Hours Running, Domestic Hot Water
  - Ignition Attempts
  - Last 10 Lockouts
- Programmable System Efficiency Optimizers
  - Night Setback
  - Anti-Cycling
  - Outdoor Air Reset Curve
  - Boost Temperature & Time

## FIRING CODES

- M7 Firing Code - California Code
- M9 Firing Code - Hot Surface Ignition with Electronic Supervision
- M13 Firing Code - CSD1 / Factory Mutual / GE Gap

## CERTIFICATIONS

ANSI Z21.13/CSA 4.9 certified  
 South Coast Air Quality Management District registered  
 Texas Commission on Environmental Quality

- Three Pump Control
  - System Pump
  - Boiler Pump
  - Domestic Hot Water Pump
- High Voltage Terminal Strip
  - 120 VAC / 60 Hertz / 1 Phase Power Supply
  - Pump Contacts with Pump Relay
- Low Voltage Terminal Strip
  - 24 VAC Auxiliary Device Relay Output - Louvers
  - Auxiliary Proving Switch Contacts - Louvers
  - 3-way Valve Contacts for Low Temperature Protection
  - Alarm on Any Failure Contacts
  - 0-10 VDC System Pump Speed Contacts
  - Runtime Contacts
  - DHW Thermostat Contacts
  - DHW Tank Sensor Contacts
  - Unit Enable/Disable Contacts
  - System Sensor Contacts - Supply and Return
  - Outdoor Air Sensor Contacts
  - Contacts for Air Louvers
  - Contacts on Any Failure
  - Cascade Contacts
  - 0-10 VDC BMS External Control Contact
  - 0-10 VDC Rate Contacts

## Energy Efficient, Cost Effective Boilers

Lochinvar first introduced Copper-Fin technology to the boiler industry some 50 years ago. Since then, we've continued to refine and perfect it - adding advanced fan-assisted combustion, hot surface ignition, a unique gasketless copper finned tube heat exchanger and highly efficient insulating materials.



## Installation Flexibility and Cost-Savings

With compact sizes that use less floor space than ever before, all Copper-Fin units are narrow enough to fit through a standard 36" doorway – an advantage most commercial boilers can't provide. Plus, thanks to special insulating materials, Copper-Fin units require only 3" clearance from combustible walls. What's more, our Stack Frame allows you to install two units in the area normally required for one. This makes it easier to fit multiple Copper-Fin boilers into cramped mechanical rooms. And you can even use a smaller diameter vent stack - up to 8" smaller than typically required for comparable atmospheric boilers - so it saves money as well as valuable mechanical room space.



## Unique Copper-Fin Heat Exchanger

The Lochinvar Copper-Fin boiler design uses a two pass heat exchanger. Water is circulated through a row of highly-efficient, finned copper tubes. The high rate of water flow creates a scouring action that prevents sediment and lime-scale buildup, common in conventional boilers, and the finned copper tubes allow maximum heat transfer efficiency. To create this special heat transfer capability, Lochinvar extrudes the fins from thick wall copper tubing to precise specifications - exactly 7 fins per inch. The result is an integrally-finned tube with a heat transfer ratio 9 times greater than a plain copper tube.

## Heavy-Duty Gasketless Design

What's more, advanced casting processes allowed Lochinvar to develop a unique one-piece header system. This gasketless design provides enhanced reliability, improved durability and optimum performance - without the problems or failures common with O-rings and gaskets.

## Meets the Toughest Air Quality Standards

Because of our unique fan-assisted combustion process, the Copper-Fin exceeds today's toughest NO<sub>x</sub> emissions requirements. An independent certification laboratory test gave us a rating of less than 20 ppm - corrected to 3% O<sub>2</sub>. And less NO<sub>x</sub> means a cleaner environment.

## Enhanced to Provide Performance and Serviceability

Our enhanced Copper-Fin models offer the same reliable operation, and feature a more service friendly design. The down stream test valves and referenced gas valves are now in the upper deck for easier access, and the electrical and BMS connections have been repositioned to the front of the unit for easier installation.

The gas valves, which are referenced to the sealed combustion chamber, improve operational performance by monitoring the pressure in the sealed combustion chamber and adjusting gas flow to maintain the optimum air/fuel mixture. And the built-in air inlet filter reduces maintenance and improves performance by trapping dust and airborne particulates that can foul the burners and blowers.

With dual sight glasses (one on each end), you can easily monitor burner performance and flame characteristics throughout the entire combustion chamber.

The operator interface panel provides two-stage electronic temperature control and comprehensive diagnostic status without opening the control panel. Its user friendly design simplifies service while providing additional diagnostic information through a series of LEDs.

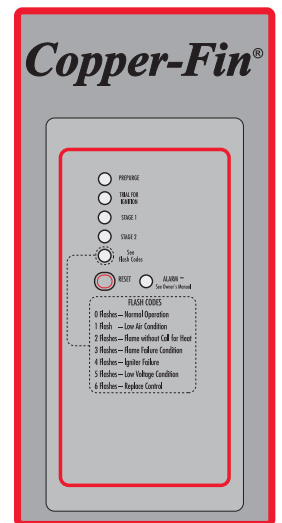

UP TO 81% THERMAL EFFICIENCY



STACK FRAME

# Copper-Fin® Boiler Dimensions & Specifications

Copper-Fin®

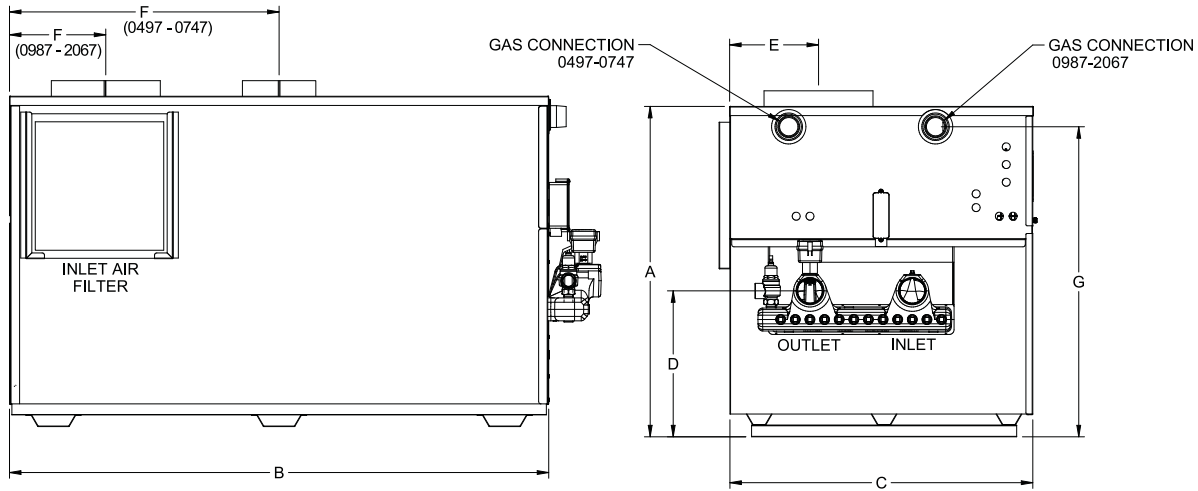

Copper-Fin Heating Boiler					Dimensions & Specifications									
Model Number	Input Max MBH	Heating Thermal Efficiency	Capacity MBH	Net I=B=R MBH	A	B	C	D	E	F	G	Gas Conn.	Vent Size	Shipping Weight
CBN0497	495	81%	401	349	31-1/2"	45-1/4"	22-1/4"	12-1/2"	9-1/2"	22-3/4"	29-1/2"	1-1/4"	6"	440
CBN0647	645	81%	522	454	31-1/2"	56-3/4"	22-1/4"	12-1/2"	9-1/2"	28-1/2"	29-1/2"	1-1/4"	8"	510
CBN0747	745	81%	603	524	31-1/2"	64"	22-1/4"	12-1/2"	9-1/2"	32"	29-1/2"	1-1/4"	8"	550
CBN0987	985	81%	798	694	36"	48-1/4"	33-1/2"	15-3/4"	8-1/2"	8-1/2"	33-3/4"	2"	10"	845
CBN1257	1255	81%	1,017	884	36"	58-1/2"	33-1/2"	15-3/4"	9-1/2"	10-1/2"	33-3/4"	2"	12"	905
CBN1437	1435	81%	1,162	1,010	36"	68-3/4"	33-1/2"	15-3/4"	10-1/2"	10-1/2"	33-3/4"	2"	12"	1050
CBN1797	1795	81%	1,454	1,264	36"	82-1/4"	33-1/2"	15-3/4"	11"	11"	33-3/4"	2"	14"	1193
CBN2067	2065	81%	1,673	1,455	36"	92-1/2"	33-1/2"	15-3/4"	11"	11"	33-3/4"	2"	14"	1350

Notes: Change 'N' to 'L' for LP gas models.  
No deration on LP models.

Water connections for models CB 0497-747 are 2" NPT on 6-1/2" centers.  
Water connections for models CB 0987-2067 are 2-1/2" NPT on 11-1/4" centers.

## Standard Features

- 81% Thermal Efficiency
- Electronic Temperature Control
- Fan Assisted Combustion
- Sealed Combustion Chamber
- Stainless Steel Burners
- Low NOx Operation Exceeds the most Stringent Air Quality Requirements
- ASME Copper Finned Tube Heat Exchanger
- 160 psi Working Pressure
- Gasketless Heat Exchanger Design
- Pump Relay w/ Delay
- Down Stream Test Valve
- Referenced Gas Valves
- Loch-Heat Ceramic Tile Combustion Chamber
- Hot Surface Ignition
- Adjustable High Limit w/ Manual Reset
- ASME Pressure Relief Valve
- Temperature & Pressure Gauge

- Flow Switch
- 24 Volt Control System
- BMS Terminal Strip
- Combustion Air Filter
- Freeze Protection
- 10 Year Limited Warranty on Heat Exchanger (See warranty for details)

## Optional Equipment

- Alarm Bell
- Contacts on any Failure & Runtime
- Contacts for Air Louvers
- Cupro-Nickel Heat Exchanger
- High & Low Gas Pressure Switch w/ Manual Reset
- Outdoor Reset Control
- Manual Reset Low Water Cut-Off w/ test
- Stack Frame
- MP<sup>2</sup> Sequencer

## Available Firing Systems

- M9 Hot Surface Ignition with Electronic Supervision (Standard)
- M13 GE GAP/FM/CSD1
- M7 California Code

## Venting

- Outdoor Vent Cap

Registered under U.S. Patent # 5,989,020

## Lightweight, Flexible and Energy Efficient

Copper-Fin gas-fired atmospheric boilers are high-efficiency boilers that save space, save money, are lightweight, and are simple to service and install. Copper-Fin boilers are equipped with a built-in draft hood, a highly efficient copper finned tube heat exchanger, our own specially designed two-stage electronic control system, and they are approved for installation on combustible floors. Models are available with inputs from 315,000 to 500,000 Btu/hr.



## Two-Stage Control System



The boiler's two-stage electronic temperature control provides flexibility and saves fuel by closely matching heat output to system demand. On colder days the boiler fires at full output, and in warmer conditions the boiler reduces heat output to save energy and reduce boiler cycling.

During the majority of the heating season, less than full boiler output is required to satisfy the heat load. For this reason, Lochinvar has developed a two-stage firing system. Two-stage firing - standard equipment on all Copper-Fin boilers, provides dramatic fuel savings by reducing the firing rate 50%. And the two-stage firing control is ideal for applications utilizing indoor/outdoor reset.\* *\*I/O reset is available as an option.*

## Copper Finned Tube Heat Transfer

The heart of the Copper-Fin boiler is its copper finned-tube heat exchanger. With this unique gasketless design, we've combined the best of both worlds: cast iron headers for long-lasting durability, and a copper finned-tube heat exchanger for high efficiencies and fast heat transfer. The gasketless heat exchanger design reduces the risk of leaks or system failures that are common with conventional boilers. Plus, the unit's low-mass design means that water gets heated quickly. Not only is heat up time nearly instantaneous with these boilers, the energy consumption and operating costs are lower too.



## Intermittent Ignition Device

The Intermittent Ignition Device is a solid-state electronic spark-to-pilot ignition system that reduces fuel consumption. It's electronic circuitry continuously monitors the system and provides pilot gas only when there is a call for heat, eliminating the need for a continuously burning pilot, and providing an additional measure of operational safety.

## Built-In Draft Hood

The lower overall height of the draft hood makes it easier to install the Copper-Fin boiler in all applications, especially in those instances where overhead space is limited and headroom restrictions exist.

## Serviceability

This boiler is as flexible and convenient to install and service as it is efficient and compact. The heavy-duty stainless steel burners can easily be adapted for use with either natural or liquefied petroleum (LP) gas, and the boiler's design allows for easy access to all major components for servicing. The heat exchanger is designed to slide out the front of the boiler for faster maintenance, and Lochinvar backs it up with an exclusive 10-year Limited Warranty. For more information, call your Lochinvar dealer today.

UP TO 82% THERMAL EFFICIENCY

STACK FRAME



# Copper-Fin® Boiler Dimensions & Specifications

Copper-Fin®

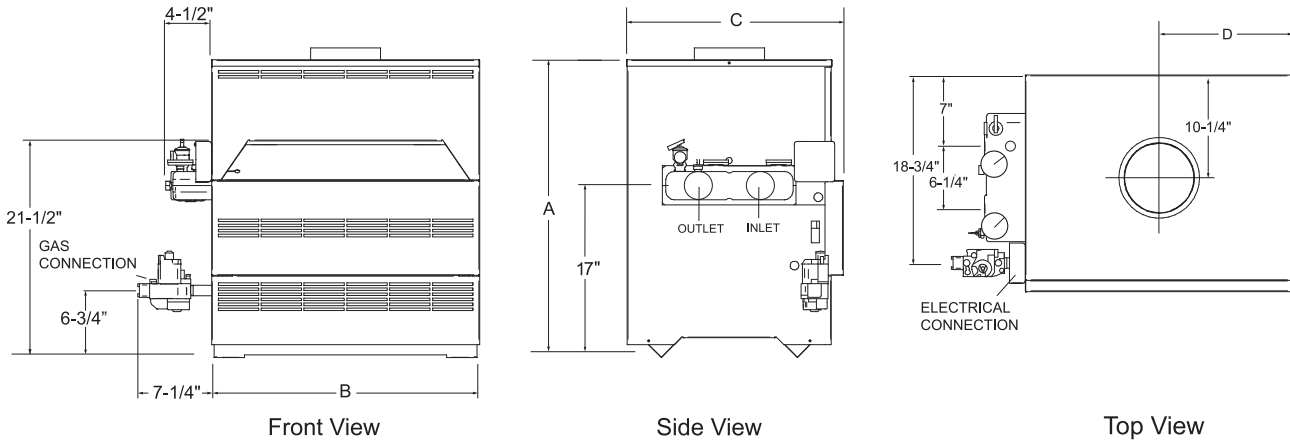

Copper-Fin Boiler					Dimensions & Specifications						
Model Number	Input MBH	Thermal Efficiency %	Output MBH	Net I=B=R MBH	A	B	C	D	Gas Conn.	Vent Size	Ship. Weight
CBN360	360	82.0	295	257	29-1/2"	35-1/4"	21-1/2"	17-3/4"	1"	9"	255
CBN399	399	82.0	328	285	29-1/2"	44-1/2"	22"	22-1/4"	1"	10"	320
CBN500	500	82.0	410	357	34-1/2"	52-1/2"	22"	26-1/4"	1"	10"	345

*Notes:* Change 'N' to 'L' to denote L.P. gas models  
 No deration for L.P. models.  
 Water Connections are 2" NPT on 6-1/4" centers.  
 Performance data is based on manufacturer test results.

## Standard Features

- 82% Thermal Efficiency
- ASME Copper Finned Tube Heat Exchanger
- Gasketless Heat Exchanger Design
- Two Stage Intermittent Electronic Ignition
- 160 PSI Working Pressure
- Pump Relay
- Two Stage Solid State Temperature Control
- Two Stage Gas Valve with Built-In Manual Shut-Off
- Automatic Reset High Limit
- ASME Pressure Relief Valve
- Temperature & Pressure Gauge
- Diagnostic Flash Codes
- Built-In Draft Diverter
- CSA Design Certified for Alcove Installation
- CSA Design Certified for Installation on Combustible Floor
- Stainless Steel Burners
- Loch-Heat Ceramic Tile Combustion Chamber
- 24 Volt Control System
- 10 Year Limited Warranty on Heat Exchanger (See warranty for details)

## Optional Equipment

- Adjustable High Limit w/ Manual Reset
- Contacts on any Failure
- Contacts for Air Louvers
- Flow Switch
- Outdoor Air Reset Control
- Low Water Cut-Off
- Stack Frame
- Pump Delay/Freeze Protection
- MP<sup>2</sup> Sequencer
- 3-Way Low Temperature Valve

## Firing Controls

- M9 - Two-Stage Intermittent Spark Ignition (Standard)
- M13 - GE GAP/FM/IRI
- M7 - California Code



## The Best You Can Buy Is Now Even Better!



KNIGHT is recognized for its reliable, proven performance and high quality standards. Its award winning design assures contractors and home owners peace of mind and long term savings in operating costs.

Now, Lochinvar has raised the KNIGHT standard to even greater heights. The dramatically enhanced SMART SYSTEM™ control with color display gives installers and maintenance personnel a greater level of control than ever before. It's easier to access all the information they need to setup, troubleshoot and monitor all boiler functions. Additionally, two new cascading options allow the installer to fine-tune sequencing of multiple boiler installations.

More than ever, KNIGHT is the best choice for traditional hydronic space heating, radiant floor heating and domestic hot water applications.



The new SMART SYSTEM™ is the most advanced integrated boiler control on the market today.

**Larger LCD Screen** - Displays more information.  
**Soft Keys** - For simple programming.

**Navigation Dial** - For fast transitions from screen to screen and easy adjustment of settings.

**USB Port** - USB port permits connection to a laptop computer. SMART SYSTEM PC software may be used to troubleshoot and program KNIGHT® functions, set date and time, monitor historical data, including faults, trends and energy consumption.

### Built-in Cascading Sequencer

When multiple KNIGHT boilers are installed together, the SMART SYSTEM built-in sequencer can be set for "Lead-Lag" cascade or "Efficiency Optimized" cascade operation.

95% AFUE



STACK FRAME



### Advanced Negative Regulation Technology

KNIGHT safely and reliably operates with supply gas pressures as low as 4 inches water column. Plus "Neg/Reg" technology automatically adjusts gas pressure to ensure the correct volume of fuel and air entering the burner.

### Direct-Spark Ignition

With each call for heat, two electrodes ignite the fuel/air mixture. A third electrode then senses for flame. The SMART SYSTEM will generate a soft lockout and display a fault if ignition does not occur.

### Fully Modulating Burner with 5:1 Turndown

The SMART SYSTEM allows fully modulating combustion with 5:1 turndown. The burner can fire as low as 20% of maximum input and modulates the firing rate up to 100% as demand increases. A woven stainless steel mesh enclosed burner tube fires in a 360° pattern along the entire length of the primary heat exchanger.

### Two-in-One Stainless Heat Exchanger

A primary heat exchanger combined with a secondary heat exchanger captures flue gas heat and condenses to utilize available latent energy. The stainless steel, pH-tolerant design features a weld-sealed assembly with no O-rings or gaskets and does not require special glycol. ASME Section IV approved and stamped



# KNIGHT® Boiler Dimensions & Specifications



Models:  
KBN 081-211

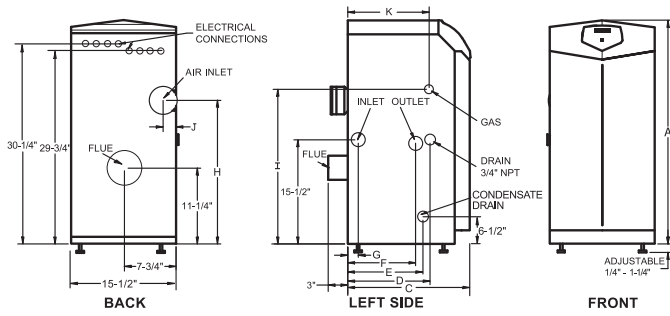

Model:  
KBN286

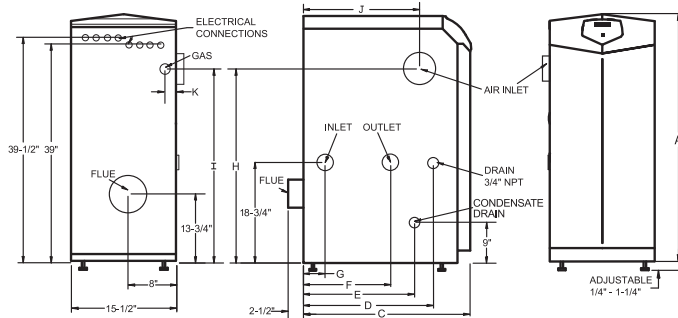

Model Number	Min. MBH	Input Max. MBH	AFUE %	Heating Capacity MBH	NET I=B=R MBH
KBN081	16	80	95.0	74	64
KBN106	21	105	95.0	97	84
KBN151	30	150	95.0	139	121
KBN211	42	210	95.0	196	170
KBN286	57	285	95.0	267	232

## DIMENSIONS AND SPECIFICATIONS

A	C	D	E	F	G	H	I	J	K	Gas Conn.	Water Conn.	Air Inlet	Vent Size	Shipping Wt. (lbs.)
33-1/4"	14"	7"	5-3/4"	5"	3"	20-1/2"	22"	1-3/4"	6-1/2"	1/2"	1"	3"	3"	125
33-1/4"	14"	6-1/2"	5-3/4"	4-1/2"	1-1/2"	20-1/2"	22"	1-3/4"	6-1/2"	1/2"	1"	3"	3"	129
33-1/4"	18"	12-1/4"	11-1/2"	10"	1-1/2"	21-1/4"	23"	1-3/4"	12"	1/2"	1"	3"	3"	157
33-1/4"	22-1/4"	16-1/2"	15-3/4"	14-1/4"	5-1/4"	21-1/4"	23"	1-3/4"	16-1/4"	1/2"	1"	3"	3"	172
42-1/4"	19-3/4"	12-3/4"	13-1/2"	6"	2"	34"	31"	11-3/4"	4-1/4"	3/4"	1-1/4"	4"	4"	224

Notes: Indoor installation only. All information subject to change. Change "N" to "L" for LP gas models.  
Net ratings based on piping and pick-up allowance of 1.15

## SMART SYSTEM™ FEATURES

- SMART SYSTEM Digital Operating Control**
  - Multi-Color Graphic LCD Display with Navigation Dial and Soft Keys
- Three Setpoint Temperature Inputs**
- Built-in Cascading Sequencer for up to 8 Boilers**
  - Cascade Multiple Sized Boilers
  - Lead Lag
  - Efficiency Optimization
  - Front End Loading Capability with Copper Fin II
- Outdoor Reset Control with Outdoor Air Sensor**
  - Programmable for Three Reset Temperature Inputs
- Programmable System Efficiency Optimizers**
  - Night Setback w/Override Function
  - DHW Night Setback w/Override Function
  - Anti-Cycling
  - Outdoor Air Reset Curve
  - Ramp Delay
  - Boost Temperature & Time
- Three Pump Control**
  - System Pump with Parameter for Continuous Operation
  - Boiler Pump with Variable Speed Pump Control\*
  - Domestic Hot Water Pump
- Domestic Hot Water Prioritization**
  - DHW tank piped with priority in the boiler loop
  - DHW tank piped as a zone in the system with the pumps controlled by the Smart System
  - DHW Modulation Limiting
  - Separately Adjustable SH/DHW Switching Times\*
- Building Management System Integration**
  - 0-10 VDC Input to Control Modulation or Set Point
  - 0-10 VDC Modulation Rate Output
  - 0-10 VDC Input Signal from Variable Speed System Pump\*
  - 0-10 VDC Input to Enable/Disable call for heat
- High-Voltage Terminal Strip**
  - 120 VAC / 60 Hertz / 1 Phase Power Supply
  - Three Sets of Pump Contacts
- Low Voltage Terminal Strip**
  - 24 VAC Device Relay
  - Proving Switch Contacts
  - Flow Switch Contacts
  - Alarm on Any Failure Contacts
  - Runtime Contacts
  - DHW Thermostat Contacts
  - 3 Space Heat Thermostat Contacts
  - System Sensor Contacts
  - DHW Tank Sensor Contacts
  - Outdoor Air Sensor Contacts
  - Cascade Contacts
  - 0-10 VDC BMS External Control Contact
  - 0-10 VDC Boiler Rate Output Contacts
  - 0-10 VDC Variable Speed System Pump Signal Input
  - 0-10 VDC Signal to Control Variable Speed Boiler Pump
  - Modbus Contacts
- Time Clock**
- Data Logging**
  - Hours Running, Space Heating
  - Hours Running, Domestic Hot Water
  - Ignition Attempts
  - Last 10 Lockouts
- Access to BMS Settings through Graphic LCD Display**
- Maintenance Reminder**
  - Custom Maintenance Reminder with Contractor Info
  - Installer Ability to De-activate Service Reminder
- Low-Water Flow Safety Control & Indication**
- Dual Level Password Security**
- Customizable Freeze Protection Parameters**

## STANDARD FEATURES

- Energy Star™ Qualified**
- 95% DOE AFUE Efficiency**
- Modulating Burner with 5:1 Turndown**
  - Direct-Spark Ignition
  - Low-NOx Operation
  - Field Convertible from Natural to LP Gas
- ASME Stainless Steel Heat Exchanger**
  - 30 psi ASME Relief Valve
- Vertical & Horizontal Direct-Vent**
  - PVC, CPVC, Polypropylene or SS Venting up to 100 feet
- Smart System Control**
- Condensate Trap**
- Other Features**
  - Automatic Reset High Limit
  - Adjustable High Limit w/Manual Reset
  - Boiler Circulating Pump
  - Adjustable Leveling Legs
  - Zero Clearances to Combustible Materials
  - Sidewall Vent Termination
  - 12-Year Limited Warranty (See Warranty for Details)

## OPTIONAL EQUIPMENT

- Modbus Communication
- Condensate Neutralization Kit
- Multi Temperature Loop Control
- Flow Switch
- Low-Water Cutoff w/Manual Reset & Test
- Alarm Bell
- Concentric Vent Kit
- SMART SYSTEM PC Software
- Stack Frame
- BMS Gateway to LON or BacNet

## FIRING CODES

- M9 Standard Construction
- M7 California Code



## Stainless Steel Fire Tube Heat Exchanger

The KNIGHT® Wall Mount, engineered with Lochinvar's exclusive SMART SYSTEM™ control and an array of other innovative features is far ahead of any heating boiler in its class. It promises and delivers ultimate ease of installation and maintenance. With up to 99% thermal efficiency, low-NOx emissions and a fully modulating burner, it is the best "green choice" for today's environmentally focused market.

Seven modulating/condensing stainless steel KNIGHT Wall Mount boilers are available with 55,000–399,999 Btu/hr inputs in a space-saving wall-mounted design. All are equipped for direct-vent installation with air intake and exhaust runs up to 100 feet using PVC, CPVC or AL29-4C vent materials. This range of choices is ideal for residential or light-duty applications such as small hotels, schools and office buildings. For higher-demand applications, up to eight KNIGHT Wall Mount units can be installed utilizing the built-in cascading sequencer to deliver up to 3.2 million Btu/hr heating capacity.

The new KNIGHT Wall Mount Boiler reflects Lochinvar's constant commitment to providing all the options you need to serve every application.



## Advanced Negative Regulation Technology

KNIGHT safely and reliably operates with supply gas pressure as low as 4 inches water column. Negative Regulation (Neg/Reg) technology automatically adjusts fan speed to ensure the correct volume and mix of fuel and air throughout the firing range.

95% AFUE



## Fire Tube Design

This fully welded ASME Certified stainless steel heat exchanger uses oval shaped tubes to pass heat from the products of combustion into the water stored in the vessel. To facilitate heat transfer the tubes are manufactured with dimples to slow the flue products and extract available latent energy. With a fire tube design the flue products are inside tapered passage ways and the water passed through a vessel. Since the flue products pass through tubes and the water is circulated through a larger diameter vessel a fire tube design allows for minimal head pressure loss through the boiler which allows the boiler to be installed easily into various hydronic applications.

## Water-Backed Combustion Chamber

An outstanding feature of the fire tube design is a water backed combustion chamber. By having the combustion chamber surrounded by water the Knight Wall Mount has more heating surface area. This larger heating surface area allows for efficiencies up to 99%.

## Fully Modulating Burner

The SMART SYSTEM allows fully modulating combustion with 5:1 turndown. The burner can fire as low as 20% of maximum input and modulates the firing rate up to 100% as demand increases. The burner is a single stainless steel assembly covered with woven steel mesh and fires in a 360° pattern along the entire length of the burner. This allows the compact KNIGHT to exceed the modulation capacities of units with larger multiple burners.

## Fully Modulating Burner with 5:1 Turndown

The SMART SYSTEM allows fully modulating combustion with 5:1 turndown. The burner can fire as low as 20% of maximum input and modulates the firing rate up to 100% as demand increases. A woven stainless steel mesh enclosed burner tube fires in a 360° pattern along the entire length of the primary heat exchanger.

## Direct Venting up to 100 Feet

KNIGHT offers 5 venting options and tremendous flexibility for placement of units within the building, because it permits direct-vent air intake and exhaust runs up to 100 equivalent feet using either PVC, CPVC, Polypropylene or AL29-4C stainless steel vent pipe.





# KNIGHT® Boiler Dimensions & Specifications

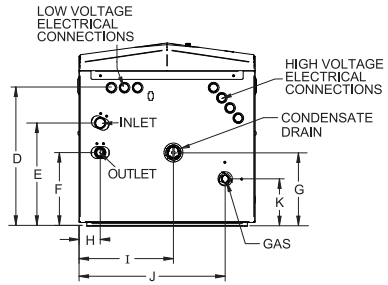
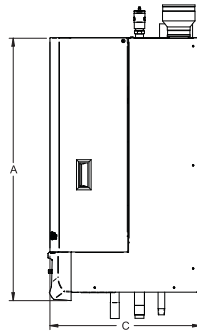
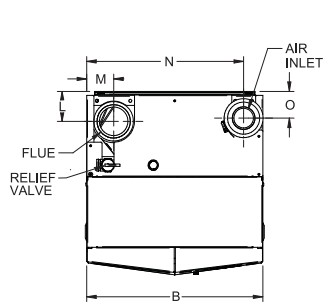

## KNIGHT HEATING BOILER

Model Number	Max. MBH	Min. MBH	AFUE %	Heating Capacity MBH	NET I=B=R MBH
WHN055	55	11	95.0	51	44
WHN085	85	17	95.0	79	69
WHN110	110	22	95.0	102	89
WHN155	155	31	95.0	144	125
WHN199	199.9	40	95.0	184	160
WHN285	285	57	95.0	264	229
WHN399	400	80	95.0**	380	323

## DIMENSIONS AND SPECIFICATIONS

A	B	C	D	E	F	G	H	I	J	K	L	M	N	O	Gas Conn.	Water Conn.	Air Inlet	Vent Size	Shipping Wt. (lbs.)
33-1/4"	18-1/2"	16"	11-3/4"	10-1/2"	6-1/2"	4"	1-1/2"	3"	14-1/2"	5-3/4"	4"	3"	16-1/4"	5"	1/2"	1"	2"	2"	139
33-1/4"	18-1/2"	16"	11-3/4"	10-1/2"	6-1/2"	4"	1-1/2"	3"	14-1/2"	5-3/4"	4"	3"	16-1/4"	5"	1/2"	1"	2"	2"	142
33-1/4"	18-1/2"	19"	14-1/2"	10-3/4"	7-3/4"	7-3/4"	2-1/4"	10"	15-1/2"	5"	3-1/4"	3"	16-1/2"	2-3/4"	1/2"	1"	3"	3"	159
33-1/4"	18-1/2"	19"	14-1/2"	10-3/4"	7-3/4"	7-3/4"	2-1/4"	10"	15-1/2"	5"	3-1/4"	3"	16-1/2"	2-3/4"	1/2"	1"	3"	3"	166
33-1/4"	18-1/2"	19"	14-1/2"	11-3/4"	8"	8"	1-1/4"	10"	16-3/4"	4-3/4"	3-1/4"	2-3/4"	16-1/2"	3"	1/2"	1-1/4"	3"	3"	175
33-1/4"	18-1/2"	19"	14-1/2"	11-3/4"	8"	8"	1-1/4"	10"	16-3/4"	4-3/4"	3-1/4"	2-3/4"	16-1/2"	3"	1/2"	1-1/4"	3"	3"	184
35-1/2"	25"	21-3/4"	17-1/2"	12-1/2"	9-1/4"	9-1/2"	2-1/4"	13-1/4"	21-1/2"	9"	4-3/4"	4"	22-1/2"	3-3/4"	3/4"	1-1/2"	4"	4"	213

Notes: Indoor installation only. All information subject to change. Change "N" to "L" for LP gas models. \*\*WHN399 value is Thermal Efficiency

## SMART SYSTEM™ FEATURES

- **SMART SYSTEM Digital Operating Control**
  - Multi-Color Graphic LCD Display with Navigation Dial and Soft Keys
- **Three Boiler Setpoint Temperature Inputs**
  - Plus Domestic Hot Water Prioritization
- **Built-in Cascading Sequencer for up to 8 Boilers**
  - Multiple Size Boiler Cascade
  - Lead Lag
  - Efficiency Optimization
- **Outdoor Reset Control with Outdoor Air Sensor**
  - Programmable for Three Reset Temperature Inputs
- **Programmable System Efficiency Optimizers**
  - Night Setback
  - DHW Night Setback\*
  - Anti-Cycling
  - Outdoor Air Reset Curve
  - Ramp Delay
  - Boost Temperature & Time
- **Three Pump Control**
  - System Pump with Parameter for Continuous Operation
  - Boiler Pump with Variable Speed Pump Control\*
  - Domestic Hot Water Pump
- **Domestic Hot Water Prioritization**
  - DHW tank piped with priority in the boiler loop
  - DHW tank piped as a zone in the system with the pumps controlled by the Smart System
  - DHW Modulation Limiting
  - Separately Adjustable Space Heat/DHW Switching Times\*
- **Building Management System Integration**
  - 0-10 VDC Input to Control Modulation or Set Point
  - 0-10 VDC Modulation Rate Output
  - 0-10 VDC Input to Enable/Disable call for heat

- **Access to BMS Settings through Graphic LCD Display**
- **High-Voltage Terminal Strip**
  - 120 VAC / 60 Hertz / 1 Phase Power Supply
  - Three Sets of Pump Contacts
- **Low Voltage Terminal Strip**
  - 24 VAC Device Relay
  - Proving Switch Contacts
  - Flow Switch Contacts
  - Alarm on Any Failure Contacts
  - Runtime Contacts
  - DHW Thermostat Contacts
  - 3 Space Heat Thermostat Contacts
  - System Sensor Contacts
  - DHW Tank Sensor Contacts
  - Outdoor Air Sensor Contacts
  - Cascade Contacts
  - 0-10 VDC BMS External Control Contact
  - 0-10 VDC Boiler Rate Output Contacts
  - 0-10 VDC Variable Speed System Pump Signal Input\*
  - 0-10 VDC Signal to Control Variable Speed Boiler Pump\*
  - Modbus Contacts
- **Time Clock**
- **Data Logging**
  - Hours Running, Space Heating
  - Hours Running, Domestic Hot Water
  - Ignition Attempts
  - Last 10 Lockouts
- **Maintenance Reminder**
  - Custom Maintenance Reminder with Contractor Contact Information
  - Installer Ability to De-activate Service Reminder
- **Low-Water Flow Safety Control & Indication**
- **Password Security**
- **Customizable Freeze Protection Parameters**

## STANDARD FEATURES

- **Energy Star™ Qualified**§
- **95% DOE AFUE Efficiency**§
- **Modulating Burner with 5:1 Turndown**
  - Direct-Spark Ignition
  - Low-NOx Operation
  - Field Convertible from Natural to LP Gas
- **ASME Stainless Steel Heat Exchanger**
  - 30 psi ASME Relief Valve
- **Vertical & Horizontal Direct-Vent**
  - PVC, CPVC, Polypropylene or SS Venting up to 100 feet
- **Smart System Control**
- **Condensate Trap**
- **Other Features**
  - Automatic Reset High Limit
  - Adjustable High Limit w/Manual Reset
  - Boiler Circulating Pump
  - Wall-Mount Bracket
  - Sidewall Vent Termination
  - Zero Clearances to Combustible Materials
  - 12-Year Limited Warranty (See Warranty for Details)

## OPTIONAL EQUIPMENT

- Modbus Communication
- Flow Switch
- Low-Water Cutoff w/Manual Reset & Test
- Alarm Bell
- Concentric Vent Kit
- SMART SYSTEM PC Software
- Condensate Neutralization Kit
- BMS Gateway to LON or BacNet
- Multi-Temperature Loop Control

## FIRING CODES

- M9 Standard Construction
- M7 California Code

\* Exclusive feature, available only from Lochinvar

§ WHN 55-285 only

**84% AFUE**

**STACK  
FRAME**

## Flexibility is the Solution™

What could be better than a high-efficiency boiler that saves space, saves money and helps resolve all your heating problems? How about one that's lightweight and simple to install, too! That's the Solution™ boiler by Lochinvar®. From the highly efficient copper finned tube heat exchanger, to our own specially designed two-stage electronic control system, the Solution boiler offers these features and many more in models up to 260,000 Btu/hr. Plus, all Solution boilers are equipped with top water connections, a built-in draft hood, and are approved for installation on combustible floors.



### Copper Finned Tube Heat Transfer

The heart of the Solution boiler is its copper finned-tube heat exchanger. With this unique gasketless design, we've combined the best of both worlds: cast iron headers for long-lasting durability, and a copper finned-tube heat exchanger for high efficiencies and fast heat transfer. The gasketless design reduces the risk of leaks or system failures that are common with conventional boilers. Plus, the unit's low-mass design means that water gets heated quickly. Not only is heat up time nearly instantaneous with the Solution boiler, the energy consumption and operating costs are lower too, with a rating of 84% AFUE.

### Two-Stage Control

The Solution boiler's two-stage electronic temperature control with built-in outdoor reset provides flexibility and saves fuel by closely matching heat output to system demand. On colder days the boiler fires at full output, and in warmer conditions the Solution boiler reduces the setpoint heat output to save energy and reduce boiler cycling.

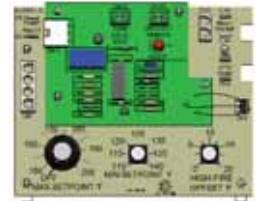

During the majority of the heating season, less than full boiler output is required to satisfy the heat load. For this reason Lochinvar has developed a two-stage firing system. Two-stage firing - standard equipment on all Solution boilers, provides dramatic fuel savings by reducing the firing rate 50%. Two-stage firing is ideal for applications utilizing indoor/outdoor reset and is advantageous in systems where the Solution boiler is used with an Squire indirect water heater to produce domestic hot water.

### PVC/CPVC Vent Kit (optional)



Vent up to 25 feet out a sidewall or rooftop with PVC/CPVC (CB 45-135).

### Simple To Service

The Solution boiler is as flexible and convenient as it is efficient and compact. For example, the heavy-duty stainless steel burners can easily be adapted for use with either natural or liquefied petroleum (LP) gas. What's more, Solution boilers allow easy access to all major components for servicing. We even designed the heat exchanger to slide out the front of the boiler for faster maintenance, and we back it all up with our exclusive 20-year Limited Warranty.

### Built-In Piping Solutions

Other boilers often require system piping upgrades which are cumbersome and expensive. The Solution boiler eliminates this problem with its built-in, performance loop. The loop maintains constant flow through the boiler when only a single zone of the system is calling for heat. This helps maintain peak system performance by keeping the copper heat transfer surface clean and operating at top efficiency. And the top water connections make replacements a snap by fitting into existing piping arrangements without additional elbows and connections.



You can depend on Lochinvar, and you can depend on the Solution boiler to deliver the comfort, convenience, and reliability you need. For more information, call your Lochinvar dealer today.

## Solution® Boiler Dimensions & Specifications

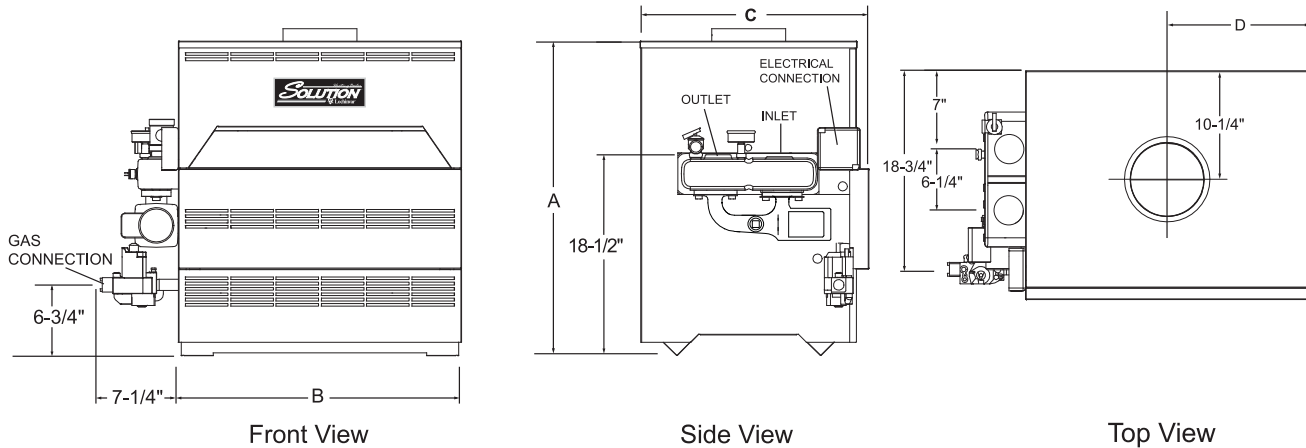

Solution Heating Boiler					Dimensions & Specifications							
Model Number	Input Max MBH	AFUE %	Heating Capacity MBH	Net I=B=R MBH	A	B	C	D	Gas Conn.	Vent Size	Shipping Weight	
CBN045	45	84.0	37	32	29-1/2"	11-1/2"	21-1/2"	5-3/4"	1/2"	4"	145	
CBN075	75	84.0	62	54	29-1/2"	15-1/2"	21-1/2"	7-3/4"	1/2"	5"	155	
CBN090	90	84.0	75	65	29-1/2"	15-1/2"	21-1/2"	7-3/4"	1/2"	5"	155	
CBN135	135	84.0	112	97	29-1/2"	19-1/2"	21-1/2"	9-3/4"	1/2"	6"	175	
CBN180	180	84.0	149	130	29-1/2"	23-1/2"	21-1/2"	11-3/4"	3/4"	7"	195	
CBN215	215	84.0	178	155	29-1/2"	26-1/2"	21-1/2"	13-1/4"	3/4"	7"	220	
CBN260	260	84.0	216	188	29-1/2"	29-1/2"	21-1/2"	14-3/4"	3/4"	8"	225	

Notes: Change 'N' to 'L' to denote L.P. gas models  
 Net ratings based on piping and pick-up allowance of 1.15

Electrical Requirements: 120 VAC / 2 AMP  
 Approved for indoor installation only

Water connections are 1-1/2" NPT  
 Performance data based on manufacturer test results.

### Standard Features

- ASME Copper Finned Tube Heat Exchanger
- Gasketless Heat Exchanger Design
- Built-In Performance Loop
- Top Water Connections
- 24 Volt Control System
- Self Diagnostic Ignition Control
- Terminal Strip
- Intermittent Electronic Ignition
- Two Stage Solid State Temperature Control
- Outdoor Reset with Outdoor Sensor
- Two Stage Gas Valve w/ Built In Manual Shut-Off
- Domestic Hot Water Priority
- 160 PSI Working Pressure
- Pump Relay
- Automatic Reset High Limit
- ASME Pressure Relief Valve
- Temperature & Pressure Gauge
- Automatic Vent Damper
- Built-In Draft Diverter
- Stainless Steel Burners
- Loch-Heat Ceramic Tile Combustion Chamber
- CSA Design Certified for Installation on Combustible Floors
- CSA Design Certified for Alcove Installation
- 20 Year Limited Warranty on the Heat Exchanger (see warranty for details)

### Optional Equipment

- Adjustable High Limit w/ Manual Reset
- Flow Switch
- Low Water Cut-Off
- Stack Frame
- Pump Delay w/ Freeze Protection
- MP<sup>2</sup> Sequencer
- PVC/CPVC Venting Kit (CB 45-135)
- O<sup>2</sup> Barrier

### Firing Control Systems

- M9 Two Stage, Intermittant Spark Ignition
- M7 California Code (CB215-260 only)

## What is a Buffer Tank/Hydraulic Separator?

A Buffer Tank/Hydraulic Separator is designed to maximize the runtime and limit the on/off cycling of a boiler while separating the boiler flow from the system flow. In applications where the minimum system load is less than the minimum output of the boiler there is a high propensity for the boiler to excessively cycle on and off due to the fact that the boiler is delivering more BTU's than the system is requiring. In this case the Buffer Tank is designed to act as a battery for BTU's. The system demand is met by using BTU's that are already stored in the tank and thus delaying the boiler from initiating a heating cycle until a minimum run time can be accomplished.

The Hydraulic Separator aspect of the tank is designed to de-couple the hydronic heating system flow from the boiler flow by acting as a "separator" so that the two independent flows do not affect one another. When the system flow is less than the minimum required boiler flow there will likely be erratic system delivery temperatures and excessive boiler cycling. These adverse affects can cause premature component failure, and in most cases, boiler efficiency will be adversely affected.

## When Should a Buffer Tank/Hydraulic Separator be applied?

A Buffer Tank/Hydraulic Separator can be applied to keep the boiler from short cycling in situations where the smallest building demand is less than the minimum rated output of the boiler and/or in situations where system flow is less than the flow required by the boiler.



## How is a Buffer Tank/Hydraulic Separator Sized?

A Buffer Tank/Hydraulic Separator is sized to provide a minimum runtime for the boiler plant. Use the equation below to find the properly sized tank for your specific application. Tank connection diameters should be sized to meet the maximum flow requirements of the application.

$$\text{Buffer Tank Capacity} = \frac{\text{Desired Run Time} \times (\text{Minimum Boiler Output} - \text{Minimum System Load})}{\text{System } \Delta T \times 8.33 \times 60}$$

- Desired Runtime- The Minimum period of time that the boiler should run before cycling off.
- Lochinvar recommends a minimum boiler runtime of no less than 10 minutes.
- Minimum Boiler Output- The amount of BTU's that will be delivered at the minimum firing rate of the smallest boiler in the plant.
- Minimum System Load- The absolute smallest heat demand of the building.
- System Delta T- The difference between the system supply temperature and system return temperature.
- 8.33- The weight of one gallon of water.
- 60- The number of minutes in 1 hour

## Buffer Tank / Hydraulic Separator Dimensions and Specifications

### Standard Features

- ASME Sec. VIII U Stamp
- 125psi (Max. Allowable Working Pressure)
- Automatic Air Vent
- 5 Year Limited Warranty
- Pre-painted Jacket
- 2" HCFC Free Foam Insulation
- Lifting Lugs

### Optional Equipment

- Temperature and Pressure Gauge
- Handhole
- Manway (300 gallons and larger)
- Custom Tapping Locations
- Custom Tapping Diameters
- Extra Tappings
- Custom Tank Sizes
- Flange or NPT Connections
- Relief Valve (Shipped Loose)

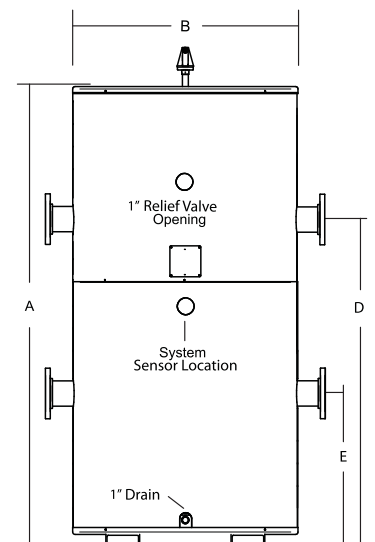
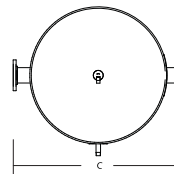

Model Number	Gallon Capacity	A	B	C	D	E	Standard Conn. Size	Shipping Wt. (lbs.)
BVU120	120	59-1/2"	32"	32"	43-3/4"	13-3/4"	3" NPT	500
BVU200	200	89-1/2"	32"	32"	73-3/4"	13-3/4"	3" NPT	900
BVU300	300	80"	40"	50"	57-1/2"	26-1/2"	4" Flange	1290
BVU400	400	80"	46"	56"	55"	29"	6" Flange	1626
BVU500	500	91"	46"	56"	66"	29"	6" Flange	1765
BVU750	750	104"	52"	62"	77"	31"	6" Flange	2330
BVU1000	1000	128"	52"	62"	101"	31"	6" Flange	3010

Notes: Custom Sizes and Configurations are Available, consult Factory for details.

Additional Recirculation & Supply/Return Connections Sizes Available, consult Factory for details.



## Reduce Short Cycling

Lochinvar's Stainless Steel Buffer Tanks are designed to provide thermal storage volume and hydraulic separation of the boiler or heat pump and the building distribution system. A properly applied buffer tank will reduce on/off cycling (short cycling), which will lead to longer runtimes, higher efficiencies and longer equipment life. Squire buffer tanks can be used in geothermal, chilled water applications, and any system with low-mass boilers.

## Thermal Storage

Hydronic buffer tanks are utilized to provide thermal storage volume when the system demand is less than the lowest firing rate of the boiler. This occurs most often when there are "micro" zones in the distribution system whose demand is below the minimum firing rate of the boiler. Under these conditions the boiler fires at its minimum rate, which is more energy than can be absorbed by the distribution system, and shuts off because of high return temperatures before the "micro" zone's call for heat is satisfied. The boiler system continues to receive a call for heat and fires again. The "micro" zone cannot absorb all the energy produced by the boiler, and again the boiler shuts off because of high return temperatures. With the volume provided by the tank the additional energy not utilized by the "micro" zone can be stored in the buffer tank and used when there are additional heating demands.

## Hydraulic Separation

Lochinvar's Squire Buffer tanks also function as hydraulic separators, effectively separating the flow in the boiler loop from the flow in the distribution system. This is beneficial when the flow rate in the distribution system is different than the flow rate of the boiler system. It can be very important when there is a variable speed pump in the distribution system whose flow rate can be less than that of the boiler pump.



**Squire**  
 Stainless Steel Buffer Tanks  
**BUFFER TANK**

## Stainless Steel Hydronic Buffer Tank Dimensions and Specifications

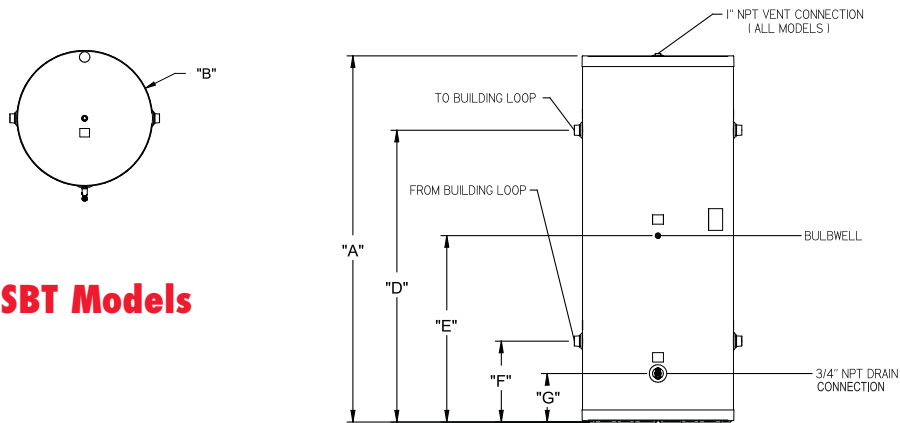

**SBT Models**

Model Number	Gallon Capacity	A	B	D	E	F	G	Supply/Return Connections	Shipping Wt. (lbs.)
SBT030	30	39-1/2"	20	28-3/4"	20-1/4"	11-3/4"	7-3/4"	1-1/2" NPT	70
SBT050	50	47	24	33-3/4"	24-1/4"	14-3/4"	8-3/4"	1-1/2" NPT	120
SBT080	80	69-1/2"	24	55-3/4"	35-1/4"	14-3/4"	8-3/4"	2" NPT	153
SBT119	119	68-1/4"	28	54-3/4"	34-1/4"	15"	9"	2" NPT	198

## Standard Features

- R-13.4 insulation for minimal heat loss
- Textured, impact resistant polymer jacket
- Light-weight 316L stainless steel tank construction
- Bulbwell
- Drain and air vent connections
- 5 year tank warranty

## A New Class of Water Heater

- 12 Total Squire Models
  - 6 Standard from 30 to 119 Gallons
  - 6 Solar with from 65 to 119 Gallons
- 316L Passivated Stainless Steel Tank
- 304L High Capacity Stainless Steel Coil
- Fully Welded Construction
- Limited Lifetime Warranty



### Stainless Steel Indirect SIT Models Dimensions and Specifications

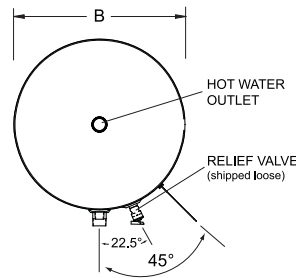
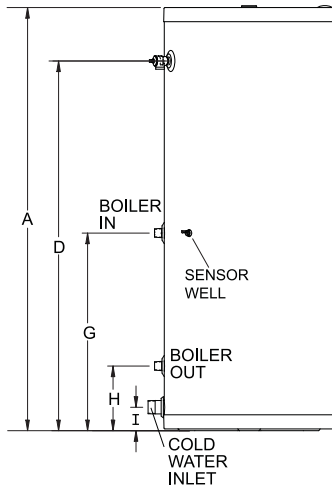

**SIT Models**

### SIT Models Dimensions and Specifications

Model Number	A	B	D	G	H	I	Domestic Water Conn.	Coil Connection Size	Shipping Wt. (lbs.)
SIT030	39-1/2"	20"	32-1/4"	21-3/4"	8-1/4"	3"	1"	1"	79
SIT040	55-1/2"	20"	48-1/2"	25-1/4"	8-1/4"	3"	1"	1"	105
SIT050	47"	24"	39-3/4"	24-1/2"	9-1/4"	3-3/4"	1"	1"	131
SIT065	60"	24"	52-1/4"	28"	9-1/4"	3-1/4"	1-1/2"	1"	147
SIT080	69-1/2"	24"	61-3/4"	28"	9-1/4"	3-1/4"	1-1/2"	1"	177
SIT119	68-1/4"	28"	60-1/4"	31-3/4"	9-1/4"	3-1/4"	1-1/2"	1"	213

Model Number	Capacity (Gallons)	Heat Source Water Volume (Gallons)	Standby Loss (°F/Hr)	Continuous Delivery (GPH)	1st Hour Delivery (Gallons)	Min. Coil Load (Btu/Hr)	Flow Rate (GPM)	Friction Loss (Ft. Hd.)
SIT030	27	1.1	1.5	160	183	99,000	14.0	3.9
SIT040	40	1.6	0.9	181	208	115,000	14.0	4.5
SIT050	52	1.7	0.9	209	255	133,000	14.0	5.3
SIT065	67	1.9	0.7	263	327	154,000	14.0	5.7
SIT080	82	2.1	0.6	285	342	171,000	14.0	6.1
SIT119	113	3.2	0.5	304	418	199,999	14.0	6.5

Performance data is based on I=B=R test results. All ratings are based on 180°F boiler water temperature.

Includes tank sensor for use with KNIGHT Heating Boiler.

Optional thermostat available for use with other boiler models.

## Stainless Steel Indirect SDT & SET Models Dimensions and Specifications

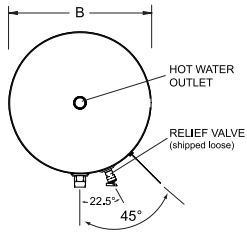

### SDT Models

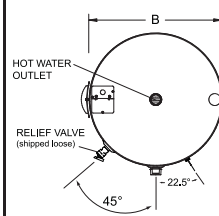
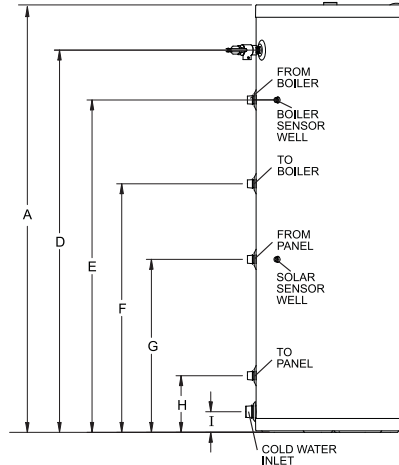

### SET Models

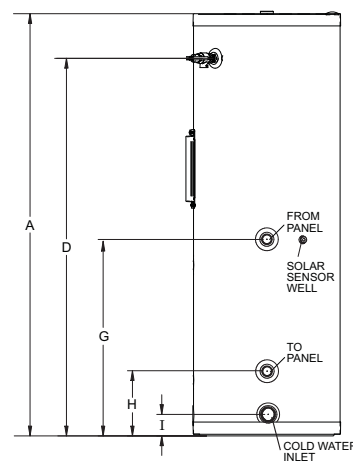

### SDT Models Dimensions and Specifications

Model Number	A	B	D	E	F	G	H	I	Domestic Water Conn.	Coil Connection Size	Shipping Wt. (lbs.)
SDT065	60"	24"	52-1/4"	47-1/4"	33-3/4"	28"	9-1/4"	3-1/4"	1-1/2"	1"	158
SDT080	69-1/4"	24"	61-3/4"	53-3/4"	40-1/4"	28"	9-1/4"	3-1/4"	1-1/2"	1"	188
SDT119	68"	28"	60-1/4"	54-1/2"	37-1/2"	31-3/4"	9-1/4"	3-1/4"	1-1/2"	1"	224

Model Number	Solar Heat Capacity (Gallons)	Solar Heat Source Water Volume (Gals.)	Boiler Heat Source Water Volume (Gals.)	Standby Loss (°F/Hr)	Continuous Delivery (GPH)	1st Hour Delivery (Gallons)	Min. Coil Load (Btu/Hr)	Flow Rate (GPM)	Friction Loss (Ft. Hd.)
SDT065	65.5	2.1	1.7	0.7	174.6	204.7	128,000	14.0	3.4
SDT080	78.4	2.1	1.7	0.6	174.6	207.1	128,000	14.0	3.4
SDT119	109.8	3.2	2.6	0.5	250.2	300.5	181,000	14.0	4.9

*Performance data based on incoming cold water at 50°F and a Delta T of 77°F. Delivery ratings for boiler coil only. Includes tank sensor for use w/ KNIGHT Heating Boiler.*

### SET Models Dimensions and Specifications

Model Number	A	B	D	F	H	I	Domestic Water Conn.	Coil Connection Size	Shipping Wt. (lbs.)
SET065	60"	24"	52-1/4"	28"	9-1/4"	3-1/4"	1-1/2"	1"	149
SET080	69-1/2"	24"	61-3/4"	28"	9-1/4"	3-1/4"	1-1/2"	1"	179
SET119	68-1/4"	28"	60-1/4"	31-3/4"	9-1/4"	3-1/4"	1-1/2"	1"	215

Model Number	Solar Heat Capacity (Gallons)	Solar Heat Source Water Volume (Gallons)	Standby Loss (°F/Hr)	Electric Continuous Delivery (GPH)	Electric 1st Hour Delivery (Gallons)
SET065	67.0	1.9	0.7	23.9	54.0
SET080	80.9	2.1	0.6	23.9	56.4
SET119	112.4	3.2	0.5	23.9	74.2

*All SET models: 4500w 240v 1 phase.*

## Another Space-Saving Idea

Lochinvar's technology not only makes our water heaters and boilers more efficient, it means they also have a smaller footprint. So they save space, as well as operating costs.

And now there's a way to get greater flexibility and reliability, save even more space, and get a system that's perfectly matched to a facility—thanks to the Stack Frame from Lochinvar.

## Match Load And Capacity

With this versatile stand, you can stack almost any combination of our ARMOR™, KNIGHT®, Copper-Fin®, Copper-Fin II®, and Solution™ water heaters and boilers so you can achieve the perfect Btu/hr capacity for each application.

For example, a facility needs a Copper-Fin II boiler with a total capacity of 1.6 million Btu/hr. Instead of installing an oversized CHN1802 unit or a smaller CHN1442 model, now you can combine two units – CHN0992 and CHN0652 models— to exactly match the facility's needs.

Plus, the total footprint of this combined system is just over 10 inches wider than the CHN0652 unit alone, making it smaller than either the CHN1802 or CHN1442 model. All thanks to the Lochinvar Stack Frame.



*Our compact KNIGHT® requires even less space when stacked on a Stack Frame.*

## No Assembly Required

Lochinvar's Stack Frame is fully factory assembled and shipped in one piece. The frame is welded using square steel tubing by certified welders. Each frame is designed and tested for each specific application.

## Added System Benefits

This modular design provides two other important benefits. First, it allows for system turndown for greater efficiency when demand is lower. And second, it ensures against system failure by utilizing two independent but complimentary units.

For residential and light commercial needs or commercial applications of up to 4 million Btu/hr the Stack Frame gives greater flexibility without a significant increase in stack size or overall system dimensions.

Once you've determined a facility's requirements and the exact models needed, utilize the charts provided to calculate total system dimensions.

**NOTE: Stack Frames are for indoor applications only.**



**ARMOR® Water Heaters (Models 151-801)/  
KNIGHT® Heating Boilers (Models 081-801)**

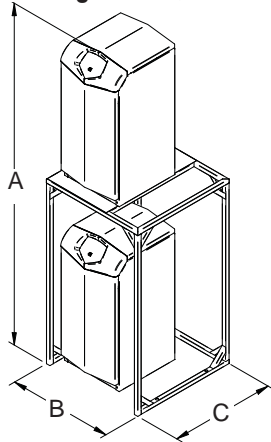

MODEL #	PART #	A*	B**	C	Wt. (.lbs)
AW 151-200	MSF3043	90-1/2"	26"	26"	60
AW 286-501	MSF3044	109"	26"	34"	72
AW 601-801	MSF30002	109"	26"	49"	108
KB 081-211	MSF3043	90-1/2"	26"	26"	60
KB 286-501	MSF3044	109"	26"	34"	72
KB 601-801	MSF3052	109"	26"	43"	94

**Note:** Heater height is 33-1/4" KB 81-121 and AW 151-200 models.  
Heater height is 42-1/2" KB 286-501 and AW 286-501 models.

**Solution™ Boilers/Copper-Fin® Water Heaters and Boilers (Models 045-500)**

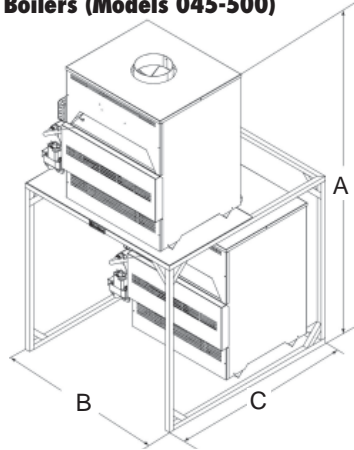

MODEL #	PART #	A*	B**	C	Wt. (.lbs)
CB 045	MSF 3034	65-1/2"	36"	39"	73
CB 075	MSF 3034	65-1/2"	36"	39"	73
CB/CW 090	MSF 3034	65-1/2"	36"	39"	73
CB/CW 135	MSF 3034	65-1/2"	36"	39"	73
CB/CW 180	MSF 3034	65-1/2"	36"	39"	73
CW 199	MSF 3035	65-1/2"	48"	39"	84
CB 215	MSF 3035	65-1/2"	48"	39"	84
CW 225	MSF 3035	65-1/2"	48"	39"	84
CB 260	MSF 3035	65-1/2"	48"	39"	84
CW 270	MSF 3035	65-1/2"	48"	39"	84
CB/CW 315	MSF 3035	65-1/2"	48"	39"	84
CB/CW 360	MSF 3035	65-1/2"	48"	39"	84
CB/CW 399	MSF 3036	65-1/2"	65"	39"	147
CB/CW 500	MSF 3036	70-1/2"	65"	39"	147

**Note:** Heater height is 29-1/2" (45 - 399) and 34-1/2" (500).

**Copper-Fin® Water Heaters and Boilers (Models 0497-0747) (Models 0987-2067)**

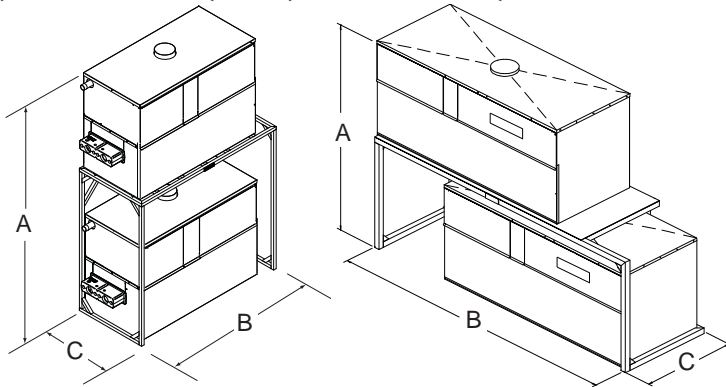

MODEL #	PART #	A*	B**	C	Wt. (.lbs)
CB/CW0497	MSF3002	81-1/2"	51"	24-1/2"	70
CB/CW0647	MSF3003	84-1/2"	70"	26"	128
CB/CW0747	MSF3003	84-1/2"	70"	26"	128
CB/CW0987	MSF3007	80"	68"	36"	170
CB/CW1257	MSF3008	80"	88"	36"	214
CB/CW1437	MSF3008	80"	88"	36"	214
CB/CW1797	MSF3009	80"	114"	36"	251
CB/CW 2067	MSF3009	80"	114"	36"	251

**Note:** Heater Height is 33-1/4" (0497-0747) & 36" (0987-2067)

**Copper-Fin II® Water Heaters and Boilers (Models 0402-2072)**

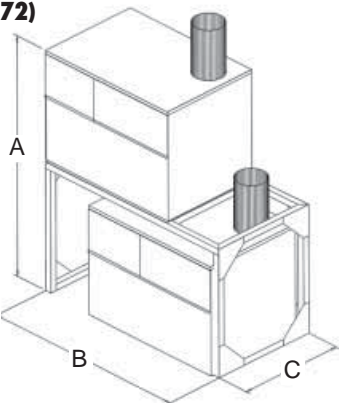

MODEL #	PART #	A*	B**	C	Wt. (.lbs)
CH/CF0402	MSF3022	67-1/2"	59"	24-1/2"	83
CH/CF0502	MSF3022	67-1/2"	59"	24-1/2"	83
CH/CF0652	MSF3023	67-1/2"	80"	24-1/2"	132
CH/CF0752	MSF3023	67-1/2"	80"	24-1/2"	132
CH/CF0992	MSF3007	80"	75"	36"	170
CH/CF1262	MSF3008	80"	95"	36"	214
CH/CF1442	MSF3008	80"	95"	36"	214
CH/CF1802	MSF3009	80"	119"	36"	251
CH/CF2072	MSF3009	80"	119"	36"	251

**Note:** Heater height is 31-1/2" (0402-0752) & 36" (0992-2072)

\* To vent connection  
\*\* Allow space for plumbing connections

## Ideal for use with Copper-Fin, Copper-Fin II and Power-Fin Boilers

When designing a boiler system with return water temperatures below 130°F it is necessary to protect the boiler from flue gas condensation. All non-condensing boilers will develop operational problems if they are continually exposed to system return water temperatures below 130°F. Typical systems that require this protection are water source heat pump systems, in-floor radiant heat systems, greenhouse heating, soil heating, process operations and manufacturing operations. Additionally, heating systems that utilize nighttime setback, night/weekend shutdown or outdoor reset control strategies should incorporate low water temperature protection.

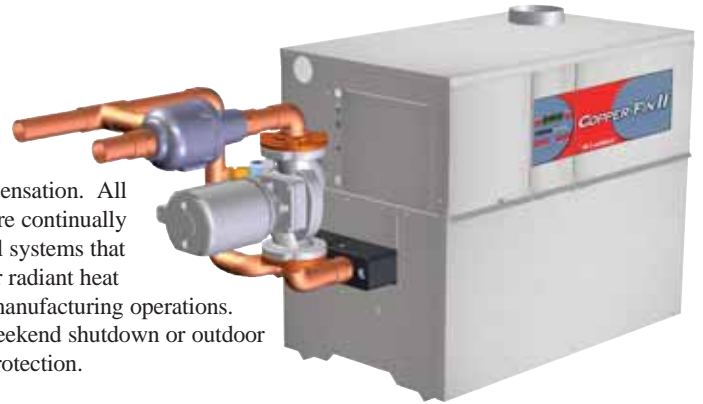

To prevent low return water temperatures to the boiler and combat operational problems, the system should be piped in a primary secondary piping arrangement with a low temperature bypass. Manual bypass systems however are not the ideal solution due to varying flow rates and firing rate of the boiler. A better alternative is Lochinvar's Low Temperature Valve, which is a self-contained automatic thermostatic 3-way valve that ensures temperatures entering the boiler remain above 130°F.

### LTV Valve Dimensions & Specifications

#### 1-1/2" LTV Valve

Up to 55 GPM flow rate  
Part Number - VAL30000

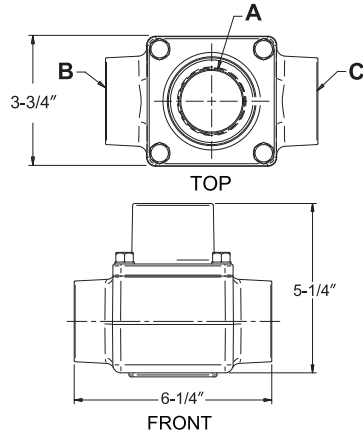

#### 2" LTV Valve

Up to 55 GPM flow rate  
Part Number - VAL3048

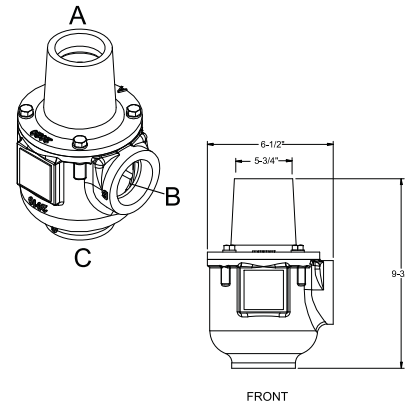

#### 2-1/2" LTV Valve

Over 55 GPM flow rate  
Part Number - VAL3047

Note: Mounting flange Included with valves.

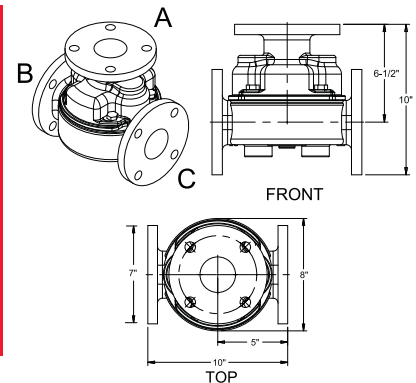

### TYPICAL PIPING

All boilers must use optional remote sensor.  
Minimum high limit setting is 205°F.  
Pump supplied by installer.

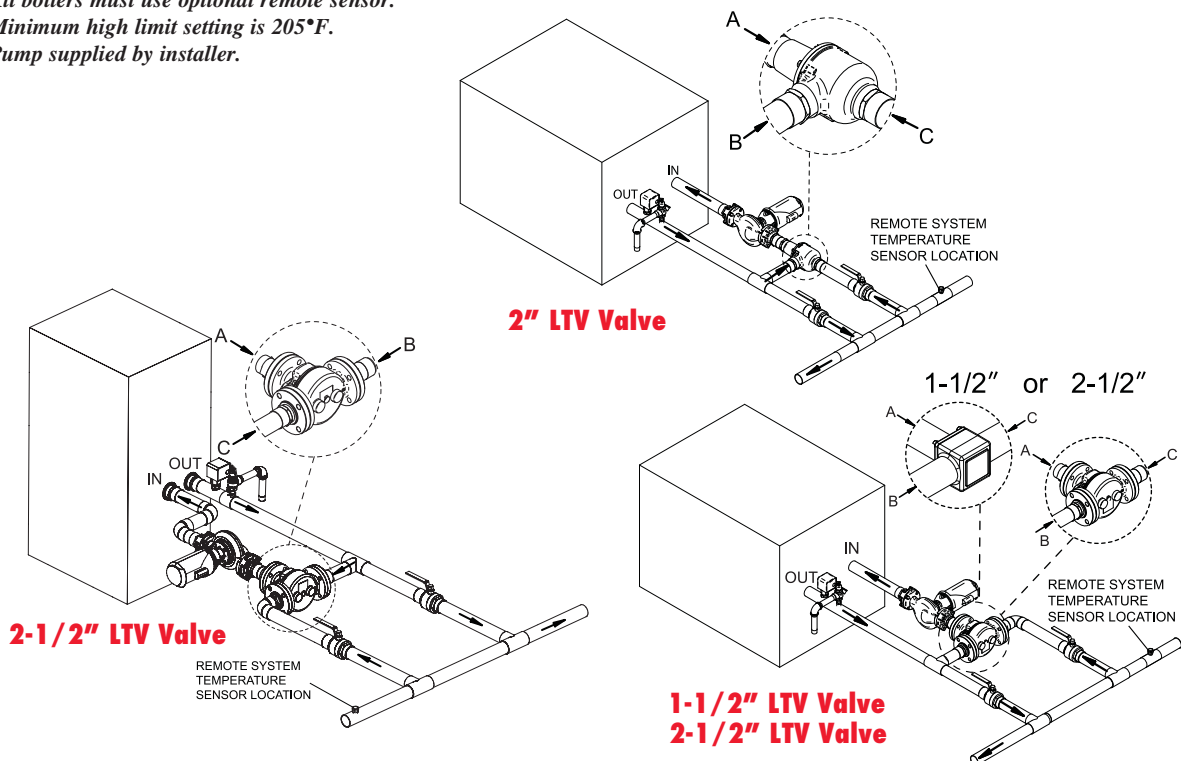

**Standard Features**

- ASME National Board Registered Pressure Vessel
- Heavy Duty Steel Boiler Vessel Housing
- 3" Fiberglass Insulation
- ASME Pressure Relief Valve(s)
- Pressure Gauge with Gauge Cock
- Feedwater Stop & Check Valves
- Full-Port Bottom Blowdown Valve
- Combination Float-Type Level Control / Low Water Cut-Off with Blowdown Valve
- Water Level Sight Gauge with Blowdown Valve
- Surface Blowoff Provision
- Low Water Cut-Off with Manual Reset & Pilot Light
- Adjustable High Limit with Automatic Reset
- Adjustable High Limit with Manual Reset
- Incoloy-Sheathed Elements
- Internal Branch Circuit Fusing
- Magnetic Contactors
- Main Supply Circuit Lugs
- 120 Volt Fused Control Transformer
- On/Off Switch with Pilot Light
- Preheat Switch with Pilot Light (above 240 kW)
- Key Locked Door
- Electric Control Panel
- Staged On/Off Pressure Switches (1, 2 & 3 Step Models)
- Proportional Solid State Step Control (models with more than 3 Steps)
- Status Pilot Light for each Stage/Step
- Listed by the Underwriters Laboratories
- 3 Year Limited Tank Warranty / 1 Year Parts Warranty (See warranty for details)

**Optional Equipment**

- Alarm Bell
- Automatic Breaker
- Automatic Feed Water Solenoid Valve
- Fused Disconnect
- Ground Fault Detector
- Kilowatt/Hour Meter
- Main Power Disconnect
- Manual Limit Toggle Switches (1 per Step)
- Automatic Timed Surface Blowoff System
- Ammeter (1 or 3 Phase)
- Volt Meter (1 or 3 Phase)
- Time Clock
- Stainless Steel Construction (100 psi/200kw Max)



**Commercial Electric Steam Boiler Dimensions & Specifications**

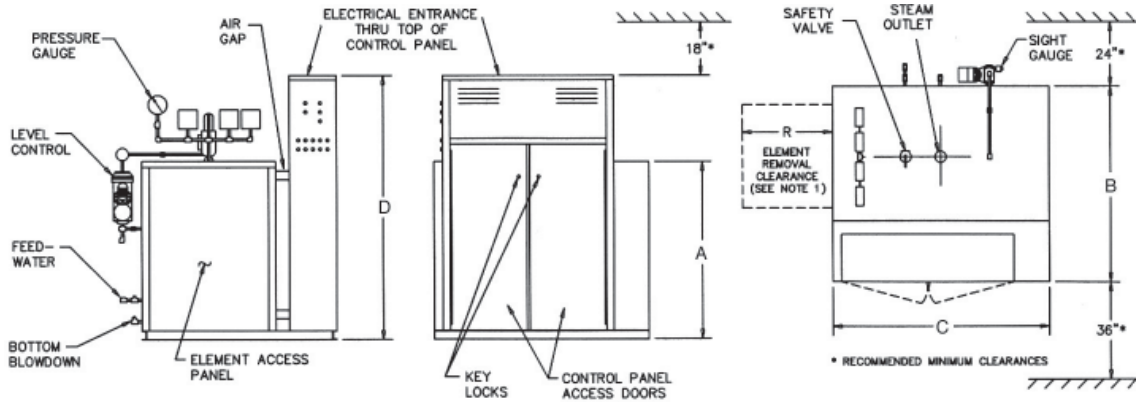

Note 1: Element removal clearance (R") is equal to 2 times the element KW.

Model Number	Max. Steam		Max. # of Elements	Connection Sizes (NPT)					Tank Data		Dimensions (Inches)				Weight (lbs)		
	Input kW	F&A 212°F (PPH)		Feed Water	Blowdown 15psi	15psi	15psi	50psi	150psi	Dims (In)	Vol (Gal)	A	B	C	D	Ship	Oper.
BS*12	60	205	3	1/2"	3/4"	3/4"	1-1/4"	1"	3/4"	12x42	20	22"	28"	50"	25"	550	650
BS*16	140	478	7	1/2"	3/4"	3/4"	2"	1"	3/4"	16x42	32	26"	32"	50"	33"	750	910
BS*16	200	682	10	1/2"	3/4"	3/4"	2"	1-1/4"	3/4"	16x42	32	26"	32"	54"	33"	800	960
BS*20	240	819	12	3/4"	1"	1"	2-1/2"	1-1/4"	1"	20x42	41	30"	36"	50"	51"	1000	1200
BS*20	320	1092	18	3/4"	1"	1"	3"	1-1/2"	1"	20x42	41	30"	36"	54"	51"	1050	1250
BS*24	360	1228	18	3/4"	1-1/4"	1"	3"	1-1/2"	1-1/4"	24x44	74	34"	40"	52"	51"	1300	1670
BS*24	600	2047	30	3/4"	1-1/4"	1"	4" FLG	2"	1-1/2"	24x44	74	34"	40"	56"	51"	1400	1770
BS*30	960	3276	48	3/4"	1-1/2"	1"	6" FLG	3" FLG	2"	30x46	124	40"	48"	60"	63"	1700	2340
BS*36	1280	4367	64	1"	1-1/2"	1"	6" FLG	3" FLG	2"	36x46	166	46"	54"	60"	63"	2100	2960
BS*42	1880	6415	94	1"	1-1/2"	1"	8" FLG	4" FLG	3" FLG	42x48	230	52"	62"	64"	81"	2800	4000
BS*48	2400	8325	122	1"	2"	1-1/4"	8" FLG	5" FLG	3" FLG	48x54	345	58"	63"	70"	87"	4600	6300
BS*54	3040	11598	152	1-1/4"	2"	1-1/4"	10" FLG	6" FLG	4" FLG	54x60	500	66"	74"	76"	89"	5600	8100

# COMMERCIAL ELECTRIC COMPACT BOILERS

## Standard Features

- ASME National Board Registered Pressure Vessel
- Heavy Duty Steel Boiler Vessel Housing
- 4" Fiberglass Insulation
- 3" NPT Inlet and Outlet Connection
- ASME Pressure Relief Valve
- Pressure Gauge with Cock
- Drain Valve
- Adjustable High Limit with Automatic Reset
- Adjustable High Limit with Manual Reset (units with more than 2 stages)
- Low Water Cut-Off
- Incoloy-Sheathed Elements
- Internal Branch Circuit Fusing
- Magnetic Contactors
- Main Supply Circuit Lugs
- 120 Volt Fused Control Transformer
- On/Off Switch with Pilot Light
- Manual Limit Toggle Switches (1 per step)
- Key Locked Door
- Electric Control Panel
- On/Off Temperature Switches (1 & 2 Step Models)
- Electronic Multi-Stage Control (3 & 4 Step Models)
- Proportional Solid State Step Control (Units with more than 4 Steps)
- Status Pilot Light for each Step
- Digital Temperature Readout (except 1 & 2 Step)
- Listed by the Underwriters Laboratories
- 3 Year Limited Tank Warranty / 1 Year Parts Warranty (See warranty for details)

## Optional Equipment

- Alarm Bell
- Automatic Breaker
- Flow Switch
- ABB Fused Disconnect
- Non-Fused Disconnect
- Ground Fault Detector
- Low Temperature Switch
- Modulating Step Control
- Kilowatt/Hour Meter
- Flanged Water Connections



## Commercial Electric Compact Boiler Dimensions & Specifications

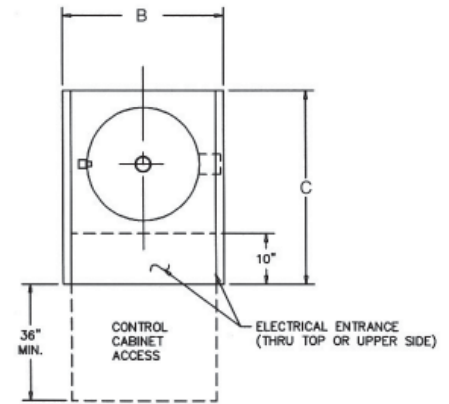
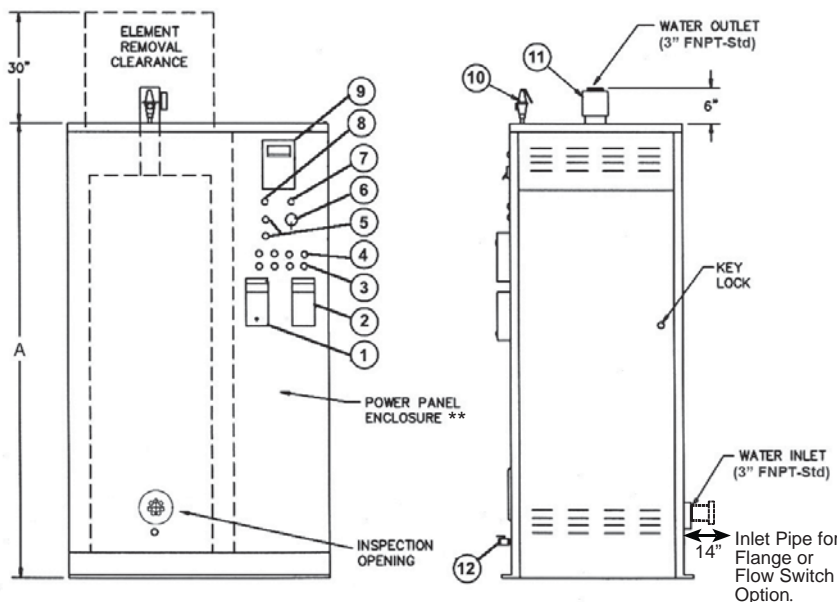

### Components

1. Temperature Limit, Auto Reset
2. Temperature Limit, Manual Reset
3. Manual Limit Switches
4. Pilot Lights, Amber (Steps "On")
5. PB Switches (Low Water Cutoff "Test"/"Reset")
6. Toggle Switch (Control Power)
7. Pilot Light, Amber (Control Power "On")
8. Pilot Light, Red (Low Water)
9. Temperature Setpoint / Control / Readout
10. Safety Relief Valve
11. Temperature & Pressure Gauges
12. Drain Valve

Model Number	Max. Flow (gpm)	Connection Sizes (NPT)	Dia (In)	Vol (Gal)	Dimensions			Weight lbs.
					A	B	C	
BW*1.**C	230	3"	12"	22	52"	24"	30"	600
BW*2.**C	230	3"	16"	36	52"	28"	34"	800
BW*3.**C	230*	3"	20"	56	52"	32"	38"	1100

\*4"/300 GPM is Optional \*\* Power Panel will be taller or wider for ABB Disconnect option. Consult factory.



**Standard Features**

- ASME National Board Registered Pressure Vessel
- Heavy Duty Steel Boiler Vessel Housing
- 3" Fiberglass Insulation
- Flanged Inlet and Outlet Connection (above 3")
- ASME Pressure Relief Valve
- Pressure Gauge with Cock
- Drain Valve
- Low Water Cut-Off with Manual Reset
- Adjustable High Limit with Automatic Reset
- Adjustable High Limit with Manual Reset
- Incoloy Sheathed Elements
- Internal Branch Circuit Fusing
- Magnetic Contactors
- Main Supply Circuit Lugs
- 120 Volt Fused Control Transformer
- On/Off Switch with Pilot Light
- Preheat Switch with Pilot Light (above 240 kW)
- Key Locked Door
- On/Off Temperature Switches (1 & 2 Step Models)
- Electronic Multi-Stage Control (3 & 4 Step Models)
- Proportional Solid State Step Control (Units with more than 4 Steps)
- Status Pilot Light for each Step
- Digital Temperature Readout (Except 1 & 2 Step)
- Listed by the Underwriters Laboratories
- 3 Year Limited Tank Warranty / 1 Year Parts Warranty (See warranty for details)

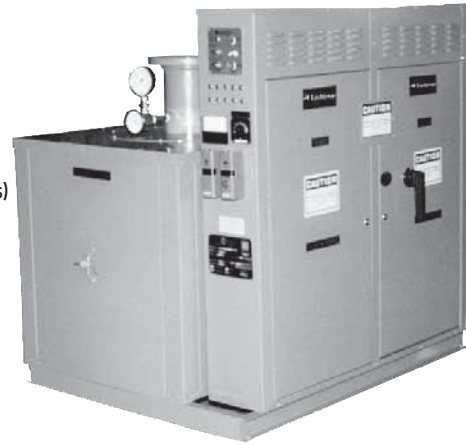

**Optional Equipment**

- Alarm Bell
- Automatic Breaker
- Flow Switch
- Fused Disconnect
- Ground Fault Detector
- Low Temperature Switch
- Main Power Disconnect
- Manual Limit Toggle Switches (1 per step)
- Kilowatt/Hour Meter

**Commercial Electric Hot Water Boiler Dimensions & Specifications**

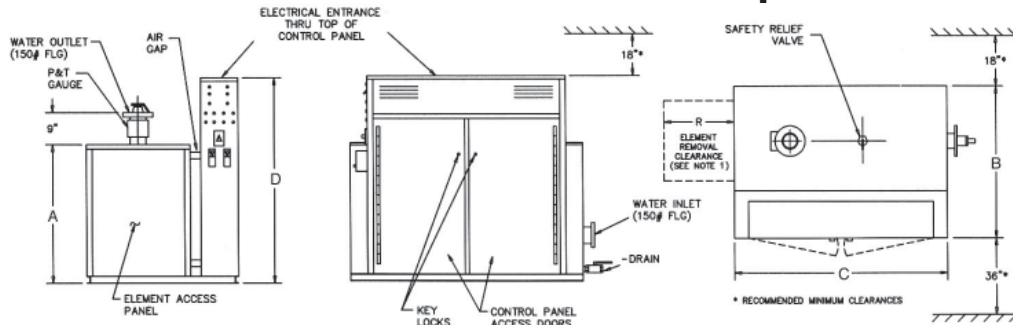

*Note 1: Element removal clearance (R") is equal to 2 times the element kW.*

*Note 2: Optional equipment may change overall boiler dimensions. Please consult factory for dimensional information.*

Model Number	Max Input kW	MBH Per Hour	Max # of Elements	Connection Sizes (NPT)		Max. Flow GPM	Tank Dims (In)	Data Vol (Gal)	Dimensions (Inches)			Weight (lbs.)		
				In/Out	Drain				A	B	C	D	Ship	Oper.
BW*16	200	682	10	3"	1"	170	16x42	30	50"	32"	26"	33"	750	990
BW*16	280	955	14	3"	1"	170	16x42	30	54"	32"	26"	51"	800	1040
BW*20	320	1092	16	4" FLG	1"	300	20x42	40	30"	36"	50"	51"	1000	1320
BW*20	520	1774	26	4" FLG	1-1/4"	300	20x42	40	30"	36"	54"	51"	1050	1370
BW*24	600	2047	30	4" FLG	1-1/4"	470	24x44	70	34"	40"	52"	51"	1300	1860
BW*24	920	3139	46	6" FLG	1-1/2"	680	24x44	70	34"	40"	56"	63"	1500	2060
BW*30	1560	5323	78	6" FLG	1-1/2"	900	30x48	125	40"	50"	60"	75"	1900	2900
BW*36	2000	6824	100	8" FLG	2"	1170	36x48	165	46"	56"	62"	87"	2400	3720
BW*42	3000	10236	150	10" FLG	2"	1840	42x50	260	54"	76"	64"	77"	3600	5760
BW*48	3600	12283	180	10" FLG	2"	1840	48x52	340	60"	82"	66"	89"	4600	7420







**Lochinvar**<sup>®</sup>  
High Efficiency Water Heaters, Boilers and Pool Heaters

**Lochinvar, LLC**

300 Maddox Simpson Parkway  
Lebanon, Tennessee 37090

P: 615-889-8900 / F: 615-547-1000



[www.Lochinvar.com](http://www.Lochinvar.com)

